

SOLAR: A Solar Powered Unmanned Aircraft System

Brandon T. Free, Joe Hayden, David Ternik, MacKenzie Hull,
Daniel Thompson, Loy McGuire

Mechanical Engineering Department, Miami University, Oxford, OH, 45056

The goal of the SOLAR senior design project is to make a solar-powered, Unmanned Aircraft System (UAS). The objective of the investigation into this type of aircraft is to test the validity of a UAS with sustained flight through solar power. Within this report the requirements needed in order to satisfy the customer, the testing done on various aspects of the project to meet these specifications, the mechanical limitations of the aircraft, and how this design accommodates them are addressed. A balance board and charge controller are used to regulate the electrical input into the system from the solar panels, and the material choice and physical design were chosen around the need for the low weight and high aspect ratio needed for a plane to fly using only solar power. The aircraft constructed for this project utilized 50 SunPower C60 solar cells and had a wingspan of 13 feet.

I. Introduction and Background

There is an ever-increasing need in industry and the scientific community for unmanned endurance drones and aircraft. Facebook, Amazon, Airbus, the military, search and rescue teams, and healthcare centers all have expressed interest for these kind of drones whose uses vary based on the specific need. Whether it is a new way of providing internet access in remote areas, surveying, package delivery, the need to expedite medical equipment, or using radar and camera technology to perform search and rescue missions, there are a plethora of suitable applications. One way to meet this need is to use solar and battery technology in order to provide long-distance, self-sustained flight for an extended time period. Harnessing sustainable forms of energy, like solar, has large implications in the transportation industry as humans try to mitigate the effects of global climate change.

This project is a part of a senior design capstone course for mechanical and manufacturing engineering majors at Miami University. The project was student created and found faculty support throughout the College of Engineering and Computing as well as a sponsor in Butler Rural Electric Cooperative. This senior design project entails designing and building a solar-powered plane with ability to be remote-controlled and equipped with a video camera to survey right of ways for the customer, Butler Rural Electric Cooperative. The solar powered glider is an experimental UAS that is classified as a Class 3, close range (less than 5000 ft of altitude), Level 0 remotely piloted vehicle; however the drone will not be able to reach a top speed of 100 mph speed as most Class 3 drones do, instead performing at low speeds for optimal solar charging efficiency.

II. Specifications and Requirements

A. Performance

Our performance specifications are intended to model real world flight situations that the UAS could encounter on its missions. In order to handle intermittent drops in sunlight, the UAS must be able to fly for at least 15 minutes solely on battery power. It must be able to follow a path set by the customer, with up to 90° turns over a 500 ft radius. With access to adequate sunlight, the battery capacity should not drop more than 8% over the course of an hour. This would allow for up to 12 hours of total flight time in ideal conditions. There must be adequate wing area to support the number of solar cells needed to charge the batteries. The design of the aircraft should be stable, with adequate control surface area to make the craft easy to fly.

B. Cost

The price goal for this UAS is to stay within the \$3,000 budget. This budget was selected on account of the funding that was received but also for a desire to keep the final product as low-cost as possible.

C. Weight

The total weight of the UAS must be less than 55 lbs in order to meet FAA regulations. To maximize the use of the limited power gathered from the solar cells, designs and materials that reduce the weight of all the components of the plane as much as possible while still providing necessary functionality must be chosen. The weight goal for the plane is less than 15 lbs.

D. Ease of Transport

The UAS must be easy to transport. Due to the large size, the UAS must be able to disassemble into more manageably sized pieces that would be able to fit into the average minivan (48 x 63 x 79 in). When disassembled, it must also be able to fit through a standard doorway (32 x 84 in). The design should allow for the UAS to be assembled and disassembled quickly and easily (under 5 min).

E. Aesthetics

Our sponsor, *Butler Rural Electric*, expressed a desire for the UAS to be featured in their magazine and their website. As such, the UAS must have high aesthetics with a clean build quality in addition to its functionality.

F. Safety

The UAS must be able to be safely operated with all potential hazards minimized. Batteries and circuit elements must be carefully designed and manufactured to minimize the risk of fire and electrical shock. Moving components such as the motor and the propeller must be positioned as to minimize risk during launch.

G. Durability

The UAS must withstand a 6 foot fall with damage limited to expendable parts (parts that can be easily purchased and replaced such as a propeller). The UAS must be stable in ideal weather conditions:

- Able to fly, fully functional in <10% cloud coverage
- Wind speed below 5 knots
- 0% precipitation
- Temperature >40°F
- Low turbulence (eddy dissipation rate of 25 or below)

H. Maintenance

The plane is designed for little to no maintenance for standard use, and is designed to endure all conditions it should incur during specified flight conditions. Parts that require regular maintenance, such as inspecting the batteries, are made to be easily accessible.

I. Battery

The batteries must be able to handle the maximum charge rate that can be supplied by the solar panels. They should also deliver the necessary power to the motor. The batteries need to be capable of receiving charge and discharging to the motor at the same time. The number of battery cells should be minimized to the number needed to power the motor and sustain flight, as the batteries are among the heaviest components on the aircraft.

J. Propulsion

The motor needs to produce enough lift for the UAS to have a successful takeoff. It should also be able to maintain a cruising speed of 15-20 knots during flight without stalling.

III. Modeling & Design

A. Electrical

The working final schematic can be in seen Appendix B. This arrangement is fully capable of:

- Providing power to the motor based on the ground pilot's input
- Adjusting the position of four control surfaces, thereby controlling the pitch, yaw, and roll of the UAS
- Logging power data throughout a flight
- Allowing a constant 25.2 V supply from the solar panels into the 6 LiPo battery cells AND balancing each cell to avoid voltage drift and overcharging
- Preventing over-discharge (cutoff at 3.25 V per cell)

By designing, testing, and creating a circuit capable of all functions listed above, the team met the PDS it laid out at the project's beginning.

1. RC components

Radio controlled (RC) airplanes are a common hobby. There are several manufacturers that supply a variety of components and kits for a wide range of airplane styles and sizes. Common to all RC aircrafts are a power source, radio receiver, control surface actuators, and a motor/engine. For strictly flight purposes, this project also required the use of an Electronic Speed Controller (ESC) and Battery Eliminator Circuit (BEC). Solar charging required a balancing board (PCM) and charge controller to also be incorporated.

The team purchased a Castle Creations Talon 90A ESC/BEC - a single device which combines both components. This ESC serves as an intermediary between the power supply, receiver, and motor. Additionally, the BEC serves as a 5V power supply specifically for the receiver. The ESC can handle up to 90 Amps of burst current and an 8S array of batteries (29.6 V nominal).

The receiver used in this design is the FrSky X8R. Receivers are generally interchangeable and this model was selected due to compatibility with the readily available FrSky Taranis X9D transmitter. Power is supplied through CH1 from the BEC. Four of the seven remaining channels were used for control surface servos. Each servo is assigned a control switch/analog stick on the Taranis, thereby allowing each to be separately controlled.

Finally, an Eflite Power 90 Brushless DC Outrunner motor was selected based on an initial ten pound weight approximation. This motor is recommended for up to a 13lb acrobatic aircraft. Given the sailplane-like flight performance this project set out to achieve, less thrust is required as compared to a 3D or moderately acrobatic craft. Given the potential for weight to be added during the design process, this motor was selected early on to be capable of supplying "reserve thrust" if necessary. Additionally, the weight of motors does not scale linearly with output thrust. The Eflite Power 46 Brushless Outrunner Motor is rated for a 5 lb aircraft and weighs 10.0 oz. The Power 90 has twice the thrust output and weighs 58% more (15.8 oz).

2. Solar Panels

Solar panel selection involved balancing efficiency, weight, durability, cost, and learning from previous designs for solar powered UAS systems. Flexible panels were desired in order to fit the shape of the airfoil so various brands and distributors were researched. The search was narrowed down to two types of solar cells: flexible thin film cells and flexible mono-crystalline cells. SunPower's c60 flexible mono-crystalline cells were selected as they were found to be four times more efficient per unit surface area than the thin film competitors. In addition, the SunPower cells had been successfully used in other solar powered aircraft applications, reinforcing the team's confidence in these cells.

The next decision was made between purchasing assembled solar panels or individual solar cells. Individual cells were selected due to price considerations and to allow for customizable panel configuration. Due to charge controller specifications, it was decided that the panels should be wired in series. Also, the configuration in which the cells were arranged was determined by the geometry of the wing surfaces. The cells were soldered together by hand using dog-bone connection tabs provided by SunPower. Wiring connections were placed at specific intervals due to the wing configuration.

Panel backing and attachment were also decided upon based on force transmission and weight considerations. It was decided to coat the upper surface of the airfoil with 1/64" plywood and mount the panels to this layer with GE Silicone #2, a clear adhesive caulk. It was decided that clear Monokote would be applied over the top of these cells in order to protect them from the elements and create a smooth surface for the airfoil without blocking out sunlight from the solar panels.

3. Charge Controller

When selecting the correct charge controller to be used in conjunction with the solar panels and batteries, several factors were taken into consideration. The main consideration was that the power output from the solar panels, which was projected to be approximately 50 watts, is compatible with the correct current and voltage needed to charge the 6S LiPo RC batteries. Because each of the two batteries are rated at 11.1 volts and wired in series, the voltages can be added, making the battery configuration 22.2 volts total. Each cell's nominal voltage is 3.7 V, whereas the float voltage, or voltage required to compensate for self-discharge of the nominal cells, is 4.2 V. This is a grand total of 25.2 V needed to sufficiently charge the lithium polymer batteries without overcharging them. With this knowledge, it was possible to spec out a custom-made charge controller to be compatible with the battery array.

4. Power Requirements

Selection of a power source was a balancing act between weight, capacity, charge/discharge rates, compatibility with off-the-shelf RC electronics, safety, and cost. Before settling on a 6S LiPo RC array - created by connecting two 3S 5200 mAh packs in series - the team also considered lithium ion cells (specifically 18650s).

The dry cell LiPo batteries were selected based on their use in nearly all similar electric RC crafts that were researched. By choosing a common product, the team ensured that the power source would be safely paired with the motor. These cells are rated for a 50 C ($50 C \times 5.200 \text{ Ah} = 260 \text{ Amps}$) discharge rate, ensuring that the packs could reliably supply the bursts of power needed for takeoff and corrective maneuvering. Similarly, the Lectron Pro packs offer a 2C ($2 C \times 5.200 \text{ Ah} = 10.4 \text{ Amps}$) charge rate; which is more than capable of charging at the current rate expected from the solar panels.

RC battery packs are outfitted with cell balancing wires that provide voltage feedback to a logic board while the pack is charged. This battery balancing board maintains an even voltage level in each cell.

5. Battery Cell Balancing

In order to extend the battery life and ensure safe battery usage over prolonged periods of simultaneous charging and discharging, a battery balancing board was selected for our application. A battery balancing board protects a battery pack from overcharging and uneven charging of its cells, which could lead to the overcharging of a specific cell. Overcharging of a LiPo battery can result in battery failure and even cause fires.

Based on the specifications of our battery pack and circuit requirements, the Tenery brand Protection Circuit Module (PCM) for 22.2 V (6S) Lithium-Ion Battery Pack with a working rating of 6A and cutoff rating of 10A was initially selected. Balancing boards compare the voltages between each of the six cells in the battery configuration and allows or restricts flow between cells in order to even out the voltages in each cell. In order to accomplish this, the cell balancing wires from the batteries are attached to logic board with a network of integrated circuit components. The negative terminals of the battery, charge controller, and ESC (Electronic Speed Controller, which provides power to the motor and all other RC elements of the aircraft) must also be connected to this balancing board. This allows the balancing board to regulate the current through the batteries in order to protect against overcharging and over-discharging of the battery packs as a whole.

The working rating of 6A with a cutoff rating of 10A were initially selected based on charging and discharging requirements for the circuit. Based on local weather conditions, the solar array, and charge controller, the anticipated charging should occur at 2A and 25.2V in good conditions. Based on the motor thrust test and drag calculations, discharging for steady and level flight were projected to also occur at this rate. Take-off conditions would require a higher current to produce enough thrust to gain altitude. Initially, the 10A discharge limit was the highest rating found for a 6S PCM from a domestic supplier.

After testing this initially selected PCM with unsatisfactory results, a new balancing board rated for 15A charging and 30A discharging was found and purchased from AA Portable Power Corp. This board met all of the specifications for the battery configuration and allowed for a full range of currents for take-off conditions.

B. Mechanical

The final design selected for the UAS was a large rectangular-wing mounted on a carbon fiber fuselage with a tail mounted on a long carbon fiber rod. This design is similar to a sailplane. The final design is documented in the drawing package of Appendix A. The final CAD model can be seen in Figure 1

1. Airfoil

After researching various airfoils that may be applicable for RC aircrafts, the options were narrowed down to two to compare. These were chosen based on the fact that they were more prevalent in sailplane use than other airfoils being considered. The SD7037 has been used for years as a popular airfoil for sailplanes and gliders. The AG35 was more recently developed and was made specifically for sailplane use. The AG35 was chosen because it had a thinner profile and produced less drag. It also had a thinner tip which would reduce the mass of the spar needed in the wing. At this point, it was determined that the optimal angle of attack of the wings should be 5 degrees to maximize lift and minimize drag.[8]

2. Wing

In order to have a lightweight design a carbon fiber spar was chosen to be the backbone for a rib structure made from balsa. This design is consistent with standard airplane modeling techniques. Over top of the rib structure, a thin, heat activated film called Monokote was added. A MATLAB script was developed to determine the proper size carbon fiber rod with an appropriate safety factor to prevent failure in consideration of the loads that it would see in flight. After making a mule, or rough prototype, to test the construction of the wing, it was decided that more balsa components should be added running the length of the wing acting as a leading edge and a trailing edge. Also, a sheet of $1/64$ plywood was added to the top surface of the wings in order to provide a stable surface for the solar panels to mount to.

The overall size of the wing was carefully adjusted to meet the criteria needed for flight. A larger wing allows for more solar panels to be mounted, but it also increases the drag forces and will cause the motor to draw more power. A larger wing also lowers the stall speed for the plane. After a few design iterations, the optimum size was decided to be roughly 13 feet in total length. This accounts for several regions of the wing where we were not able to mount solar panels such as on or near the ailerons.

In order to ensure that the wing is able to be transported, it is designed to be broken down into three sections: a center and two dihedral sections. The dihedral sections were also attached at an angle of 3° to allow for greater stability. A special dihedral connector was designed to connect these parts.

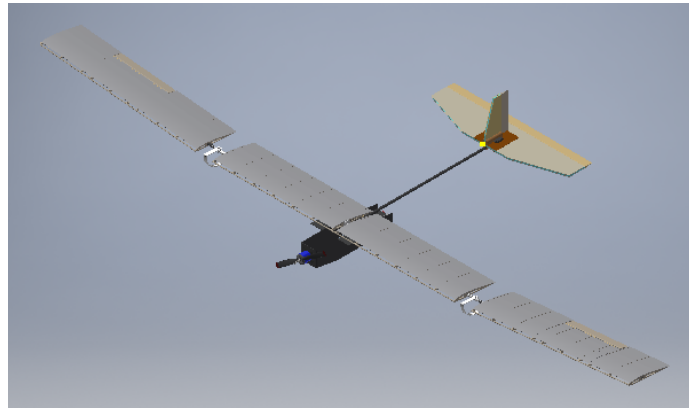

Figure 1: CAD of Final Assembly

3. Dihedral Connector

The dihedral connector was designed not only to allow for the separation of the three wing sections but also to have bumpers to act as landing gear to absorb the impact from landing and prevent parts of the UAS from catching on the ground. The dihedral connector is comprised of five pieces; an aluminum ski, a shoulder screw, a nut, and two aluminum tubes as shown in Figure 2. The first tube has an outer diameter of 0.5", which fits into the carbon fiber spar, and is bent in the middle by 5 degrees to create the angle of the dihedral. The second tube has half of its inner diameter (ID) 0.5", which fits the bent tube inside of it, and the other half was bored to a 35/64" ID, to fit the carbon fiber spar inside of it. Over the 0.5" inner diameter section of the larger tube, a flat slot was milled to create a flat surface that the aluminum ski could rest on and be bolted down to, while the sides of the slot would be narrow enough to prevent the ski from twisting. A 3/16" hole was drilled through both tubes to allow the shoulder screw to be inserted through. The aluminum skis were made from thin strips of aluminum bent to the proper shape with another strip welded across it for added stiffness. The large tube was epoxied onto the center wing spar, while the smaller bent tube was epoxied into the dihedral wing spar. To assemble these sections, the smaller tube is inserted into the larger tube until the bolt holes align, the aluminum ski is placed on top of the flat part of the larger tube, and the shoulder screw is inserted through the hole and secured by a nut on the other side.

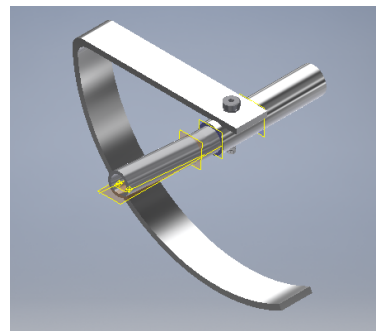

Figure 2: Model of the Dihedral Connector

4. Fuselage

A carbon fiber fuselage was designed to house all of the electronic components and to mount the motor. It has a flat surface on the front for the motor mount, and two flanges near the top that will allow it to clamp onto the center spar of the wing as shown in Figure 3. It was created in house using an aluminum mold.

In order to ensure that the electronic components were adequately protected from impact and to help hold them in place, a foam electronics tray was utilized. The tray was adjusted to ensure that the plane had a proper center of gravity based on the location of components. The geometry of the fuselage went through a few iterations in order to ensure that it would adequately hold the increasing number of electronics, while being adjustable to maintain a proper center of gravity. Components are held in place with a combination of foam, velcro, screws, and adhesive spray.

After determining that there was too much torsion in the center spar when the tail rod was mounted directly to the center spar, three wooden blocks were added to the fuselage and bolted in place. Each of the blocks had a hole through it that allowed the tail rod to be attached directly to the fuselage and for the bending moment from its weight to be spread across multiple locations. These blocks also have the added effect of stiffening the whole fuselage design and providing a back to the fuselage, which helps to prevent electronics from falling out if they were to become loose in flight.

5. Tail

The tail of the UAS is made up of two pieces of XPS foam, both laminated in balsa sheeting. There is a large (36" x 8") horizontal stabilizer with an elevator running across the back and a small (9" x 4") vertical stabilizer attached to a rudder. The surface areas of the stabilizers were initially based on volume coefficients (0.5 and 0.035 respectively) that were selected from best practice guides in order to maximize stability [8]. After reviewing the design with Dr. Fazeel Khan, it was learned that increasing the vertical stabilizer height

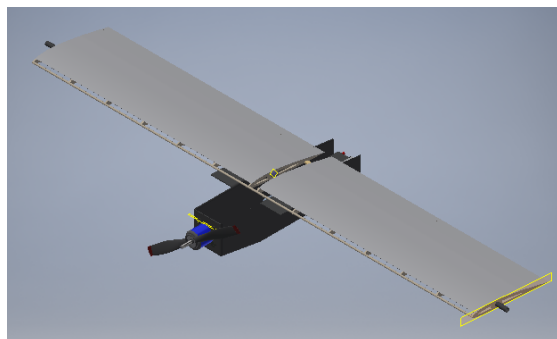

Figure 3: Model showing the fuselage connected to the center wing assembly

would allow for better rudder authority, which led to the 9" height instead of the original 5". Softwood blocks were made to attach the vertical and horizontal stabilizers and to connect a carbon fiber rod to the tail. The elevator and rudder are made of a shaped softwood and are attached with control horns and push rods to servos that move these control surfaces. Balsa blocks were installed within the horizontal and vertical stabilizers to slot in hinges to connect them to their respective control surface. Thin plywood sheeting is used to strengthen the area where the blocks are adhered and the servos are held.

To find the force that the tail will endure a Computational Fluid Dynamics (CFD) simulation was run on the model. The simulation comprised of the plane facing 20 mph winds head on, where it was found that the tail would incur a 0.4483 lbf force downwards, which is well within the factor of safety for the tail.

6. Propeller

The propeller was chosen according to the motor size and the amount of thrust to be generated for flight. The design of the UAS closely matches that of a glider, which needs to maintain a slow flight speed. This meant that a large diameter propeller with a fairly flat pitch was necessary as this design translates to more torque and less speed. Thus, a larger diameter, lower pitched propeller will move a larger volume of air at a lower speed. A 16x8 prop was chosen. This propeller has a 16" diameter and moves forward 8 linear inches per rotation.

IV. Experimentation

A. Electrical

1. Motor Thrust Testing

The E-flite Power 90 is an off-the-shelf brushless outrunner DC motor. It is recommended for acrobatic aircraft weighing between 8 and 13 pounds. The selection of the motor was based on a justified 10 pound all-up-weight initial approximation. Research guided the conservative assumption that roughly 90% of the aircraft's weight worth of thrust should be available during takeoff.[7]

A test apparatus, shown in Figure 4, was designed which allowed the motor's thrust at varying power input to be monitored. Thrust testing allows the team to verify that the system will supply sufficient thrust, determine when the motor operates most efficiently, and approximate a level flight power requirement. This data is critical for optimizing the system's net power; balancing the amount of power in from the solar cells and power supplied to the motor.

2. Solar Panel Testing

The solar panels were tested in multiple ways to find flexibility, individual efficiency, and panel efficiency.

In order to find the cell flexibility, the cells were bent and the deflection was measured. Initially, the cells were placed onto the curved airfoil surface in order to verify that they could be attached to the wing. Next, one edge of a solar cell was fixed in place and the other end was loaded in order to measure the distance that the cells could bend. Finally, the cells were bent along two axes to test their flexibility in multiple degrees of freedom.

Before soldering the solar cells together, the open circuit voltage of each cell was tested. This was accomplished by measuring the voltage from positive to negative terminal of each cell under a lamp. Using the constant radiance of an artificial light source, the open source voltages of each cell could be compared to each other. This test was also performed during assembly when multiple cells were attached in order to check the solder joints.

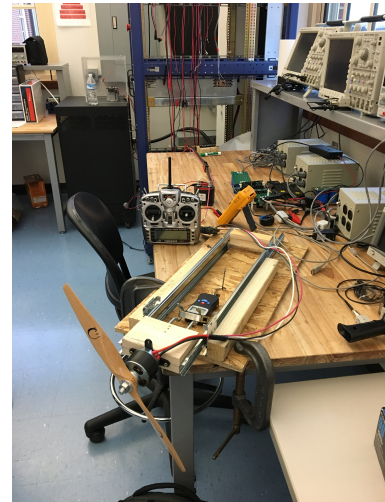

Figure 4: Thrust testing apparatus



Figure 5: Solar panel configuration

Once the panels were completed, the cells were taken outdoors into direct sunlight and connected completely as seen in Figure 5. The open source voltage across each section of cells was measured. The resistances across tabbing wires and wiring connectors were also measured. Finally the open source voltage across the entire panel layout was measured and compared to the SunPower c60 cells specifications.

3. Balance Board Testing

The Tenergy board described above in Section III.A.5 was wired into the circuit as shown in Appendix B. In order to test the circuit in a regulated environment, the solar panels were replaced with a controllable power source and the motor was again mounted on the thrust testing apparatus as shown in Figure 4. The battery cell voltages were measured and recorded before being connected to the balancing board.

First the circuit was tested without charging in order to see how the board would react to discharging only. The circuit was closed and the motor was throttled up to the following thrust levels requiring the subsequent discharge rates: 1 lb. of thrust

for steady and level flight values at 2A, 3 lbs. of thrust at 7A, 4 lbs. of thrust at 11A, and 5 lbs. of thrust at 14A. The current was measured using an oscilloscope and observations of the board's over-discharge protection were made as reported in Section V.

Next, the motor was turned off and battery cell voltages were measured. The power source simulating the solar panels was turned on and set to match the solar panel charging values under ideal conditions: 25V, 2A charging. The battery voltages were measured incrementally and compared against the previous voltages, verifying that the balancing board allowed charging and that the cells were approaching equivalent levels.

Finally, simultaneous charging and discharging were tested. The solar panel simulation and motor were both turned on and the current going to the batteries was measured by the oscilloscope.

4. Finalized Circuit Test

Finally, the panels, RC components, and charge controller were tested for their ability to supply power to the batteries while the motor is running. The battery cell voltage and panel output voltage were monitored over time while the motor was left running. Two trials were performed: one in which the thrust output was held constant and one in which thrust was varied at an intermediate point during the trial. This test serves to confirm compatibility during operation of all components as well integrating the RC circuit with the panels for the first time.

B. Mechanical

Due to the circumstances described in the Conclusion, we have been unable to do extensive flight testing. As a result a large portion of the mechanical testing was done qualitatively in order to verify the design.

1. NASA Foil SIM Testing

In order to verify some of the hand calculations performed to estimate lift and drag, an online tool was used to verify our numbers. NASA Foil SIM software has the capability to give estimates of Lift and Drag after inputting some basic characteristics of the airfoil, and the conditions that it would be flying in. Lift and Drag was measured at air speeds ranging from 10 to 25 mph and at varying angle of attack to determine what speed would be needed to get the lift force that we needed. The drag force resulting from the tail at different speeds was also tested to determine the total expected drag due to the flight surfaces. Because the wing and tail comprise most of the area of the aircraft, this number is a good estimate of how much thrust the motor would need to provide in steady flight.

2. *Electronics Housing*

The Circuit was assembled and placed in the electronics housing to determine if it was adequate for flight. There were several areas of concern that were tested. First, the housing should be large enough to hold of the electronics, with room to adjust the components to maintain a proper CG. The housing should be rigid enough to hold the weight of all the electronics (5 lbs). The receiver antennae should not be shielded by the Carbon Fiber material.

3. *Epoxy Torsion*

Several of the joints relied on a bond between carbon fiber tubing and aluminum rods. In order to ensure that these joints were strong enough, torsion tests were done by placing the aluminum place in a table vise, and twisting the carbon end with slip-joint pliers.

4. *Wing Bending*

The flexibility of the wings and the subsequent deformation it causes to the attached wood pieces was tested to determine if the wings could hold the weight of the rest of the UAS when in flight. This was done by attaching the fuselage to the wing with all electrical components within and the motor and motor mount attached. The plane was then lifted from the dihedral connectors and deflection observed.

5. *Drop Test*

Drop tests were done to verify the durability of the UAS during landing. Landing was simulated by dropping the UAS from heights varying from 6 to 24 inches onto a fully rigid surface. Failure criteria included fracture, misalignment, and severed wire connections.

6. *Panel Mounting*

In order to test the effects the efficiency of the solar panels after mounting them on the wing, a small wing test section was used. Two solar panels were adhered to the plywood on the wing section using dabs of silicon. Then, clear Monokote was applied over the panels. Open source voltage readings were taken.

7. *Ease of Transport*

The aircraft's ability to be transported was tested by disassembling the UAS, bringing it out of the workspace room, and loading it into a minivan.

8. *Weight/Center of Gravity*

To verify that the weight limitations were met, each section of the UAS was weighed. The center of gravity was then found using a CG machine that held the constructed plane and measured its center of gravity.

V. Results

A. Electrical

1. *Motor Thrust Testing*

The motor thrust test resulted in voltage, current, power, and thrust data. This data was plotted as shown in Figure 6. Lines for the anticipated drag force of 1 lb. were overlaid onto graphs 6(a-c) in order to identify realistic current and power requirements for the aircraft. It can be seen from plots 6(a) and (b) that the plane will require approximately 50W (2A at 25V battery level) in order to maintain steady and level flight. Also, Figure 6(c) shows that this is the motor's most efficient range in terms of pounds of thrust per watt. This validates the selection of the motor and is encouraging for the success of solar powered flight. Figure 6(d) shows the battery voltage drain during steady and level flight (1 lb. thrust). Extrapolating the voltage drop of less than 5% over a 10 minute period would give the batteries more than a 3 hour lifespan without solar charging. This lifespan is much greater than necessary to account for takeoff of the plane or

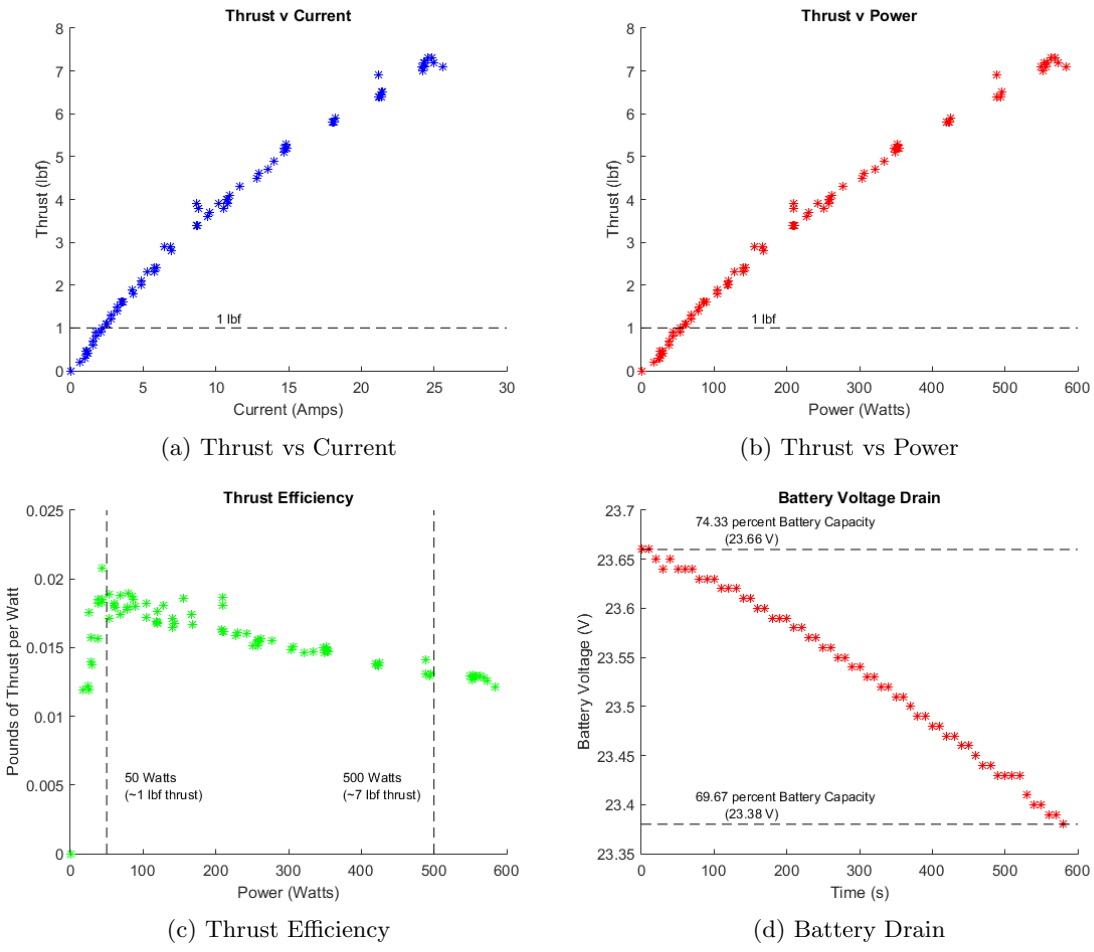

Figure 6: (a) Motor Thrust vs. Current required with fully charged batteries (b) Motor Thrust vs. Power required (c) Thrust Efficiency in terms of pounds of thrust per watt provided to the motor (d) Battery Voltage Drain over a period of 10 minutes at 1 lb. of thrust to represent steady and level flight

flight under patches of cloud cover. This provides the aircraft with an adequate charge buffer as to eliminate risk of the aircraft running out of energy during flight.

2. Solar Panel Testing

The flexibility of the solar panels was found to be adequate to fit onto the most extreme curves of the airfoil surface. The maximum displacement of a solar cell with a with one end fixed was 1.5" as seen in Figure 7. However, when the solar panel was bent along one axis it was not flexible in a second degree of freedom. Attempting to bend the panel along a second axis always resulted in fracture of the panel. This meant that the solar panels would not survive deflection along the length of the wing if they were rigidly fixed along the bent contour of the upper surface of the airfoil.



Figure 7: Solar panel flexibility test

The testing of individual cells during assembly resulted in the discovery of many inefficient cells or duds. A high quality cell was considered to have an open circuit voltage (V_{oc}) of 5.0V under artificial light. A cell was determined to be a dud if it measured below 4.0 V_{oc} in the same lighting. Approximately 25% of the purchased cells were found to be duds. This greatly increased manufacturing time for the solar panels as tabs had to be soldered and then removed from duds in order to measure the V_{oc} . However, it allowed the panels to be manufactured using efficient cells.

Testing the solar cells under direct sunlight revealed the success of the manufacturing procedures. The voltages of each section of the solar panels are shown in Table 1.

Based on the manufacturer-provided information of the SunPower C60 solar cells, the average open source voltage of $0.598V_{oc}$ per cell is projected to translate to approximately 0.5V effective voltage per cell. This means that the solar cells will be producing energy at approximately 25V with current varying based on the radiance of the sun. Based on Table 1, it can also be seen that there were some minor losses in the tabbing wires and connectors contributing to the 0.1V difference between the sum of the panel sections and the complete panel configuration. These losses are to be expected and are acceptable as they are 0.3% of the open circuit voltage of the entire solar panel system.

Table 1: Open Circuit Voltages of Solar Panels by Wing Section

Panel Section	Number of Cells	Open Circuit Voltage (V_{oc})
Right Dihedral	13	7.85
Left Dihedral	13	7.90
Front Central Row	12	7.10
Back Central Row	12	7.25
Complete Panel	50	29.91
Averaged Cell Value	1	0.598

3. Balance Board Testing

When the battery balance board tested without charging, it was found that the battery balancing board did not infringe on the discharge rate of the board until the discharge rate reached the rated 10A threshold. After this point the board began clipping (shutting off instantaneously in order to prevent over-discharge) though the board did not shut down the circuit completely. The clipping was observed by measuring the current to the motor with an oscilloscope. The clipping began around 3.5 lbs. of thrust, however, when full throttle was applied the motor could still produce over 5 lbs. of thrust. This showed that driving the plane

over 3.5 lbs of thrust could overtax the MOSFETS on the balancing board, potentially burning out these circuit components and leading to premature failure. Due to these results, the aircraft would need to be limited to 3 lbs. of thrust for takeoff and climbing with this specific battery balancing board.

Tests with only charging and no load from the motor verified that the balancing board allows charging and that the cells approach equivalent levels upon charging.

Simultaneous charging and discharging tests revealed that at 1.1 lbs. of thrust there was no current to the batteries, meaning that in idealized conditions with 1.1 lbs. of drag, the plane would be flying with net zero charging. These approximations align with projected charging and drag calculations.

In conclusion, the balance board testing revealed that the battery balance board would be adequate, but would limit the UAS's maximum thrust to 3 lbs. in order to prevent premature failure of the balancing board. In essence, a board rated for higher discharging would be ideal. Due to these results a new board with a 15A charge rating and 30A discharge rating was purchased for use in the finalized circuit.

4. Finalized Circuit Test

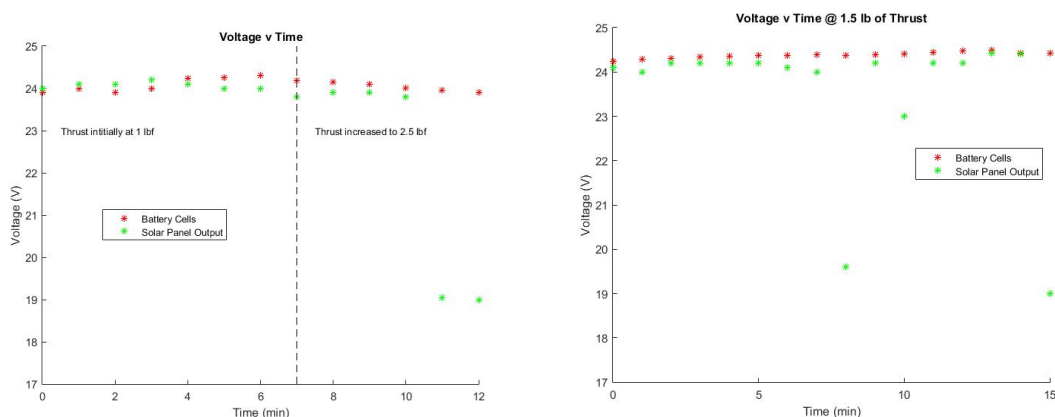

Figure 8: (a) Voltage vs Time for batteries and panels with a step up in thrust part way through (b) Voltage vs Time for batteries and panels with a constant thrust level of 1.5 lbf

The finalized circuit test was a complete success. The results of this test are shown in Figure 8. The sky was completely clear during the test. The batteries, motor, RC components, balancing board, and charge controller all behaved exactly as expected. The simultaneous charging and discharging aspects of the PDS have been completely met. The only remaining step is to test during flight.

The data indicates that at just over the anticipated level flight power requirement (1.5 lbf thrust), the batteries are *gaining charge* at a rate of $\approx 0.6 \frac{V}{hr}$. With a 1.5 factor of safety to the model, it can be predicted that in ideal conditions the battery charge level will break even during level flight.

B. Mechanical

1. NASA Foil SIM Testing

The testing for our aircraft was done in two parts: first estimating the lift and drag associated with the wing at varying speeds and angle of attack, and estimating the drag force from the tail at varying speeds. The program requires the input of several different parameters to describe the wing and its airfoil. These parameters are shown in Table 2

In order to estimate the drag force of the tail, it was approximated as a simple plate incident at 0° . The Parameters used for this test are shown in Table 3

The results of the testing are shown in Figure 9. The first parameter studied was the Lift Drag Coefficient which gives an idea of how efficient the aircraft is. Figure 9a shows that a lower angle of attack is higher, and that the coefficient starts to level off near our cruising speed. For best efficiency we would fly in the region above 20 MPH.

Table 2: Parameters for Wing Airfoil Testing

Total Airfoil Length	13.5	ft
Chord Length	0.9167	ft
Total Wing Area	12.375	ft ²
Airfoil Type	Flat Bottom	
Camber	2.3	%
Thickness	8.7	%
Neutral Angle	4.24	Degrees

Table 3: Parameters for Tail Testing

Airfoil Type	Plate	
Angle	0	degrees
Camber	0	%
Thickness	4.5	%
Chord	0.4582	ft
Total Length	3.706	ft

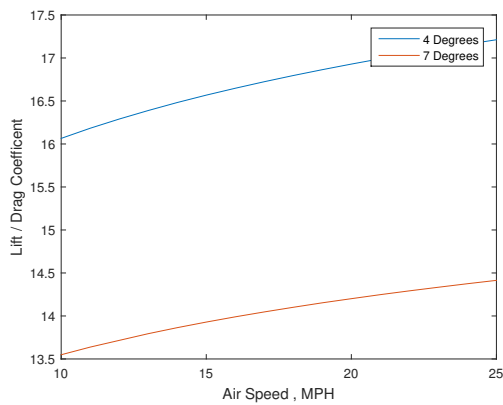

(a) Lift Drag Coefficients

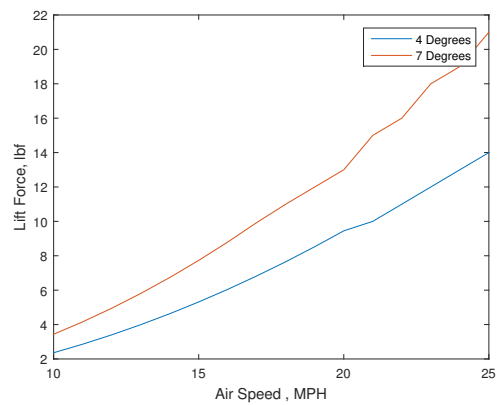

(b) Lift Forces

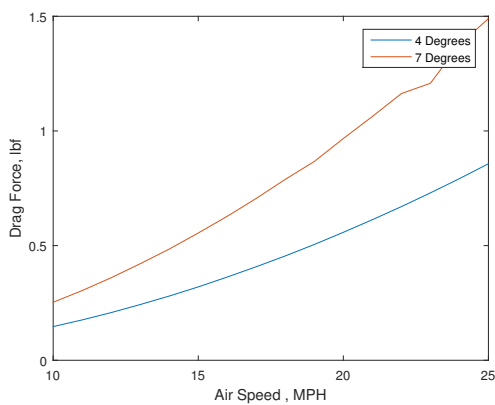

(c) Drag Forces for the Wing

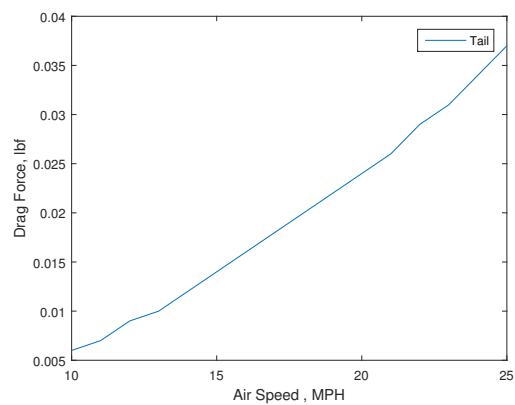

(d) Drag Forces for the Tail

Figure 9: Results of the NASA Foil SIM testing done on the wing and the tail assembly

The next result studied is the lift force. Knowing that the final weight of the aircraft should be between 10 and 12 lbs, Figure 9b shows that the plane would need to fly at least 22 MPH at with a 4 degree angle of attack to generate the necessary lift to fly.

Finally, Figures 9c and 9d can be used to estimate the drag force the craft would experience at the target cruising speed. A high estimate of 1.5 lbs was used as the sum of drag force experienced by the wing and the tail, which is well within the range of thrust that our motor can output.

2. *Electronics Housing*

The first iteration showed that the electronics would not easily fit into the fuselage housing despite previous CAD verification. Extra room was added for foam protection, wire runs, and for adjustability to maintain a proper center of gravity. The initial design was also not very rigid and deflected very far under the load of the electronics. Wood reinforcement blocks were added to attach to the tail rod as well as to make the fuselage more rigid. An adjustable motor mount was also attached so that the motor would have more cooling and be movable to determine the best center of gravity.

Range testing was performed with the receiver inside and outside of the housing to determine the effects of shielding due to the carbon fiber material. It was determined that the carbon greatly affects the range of the transmitter, and that the antennae would need to be mounted outside of the fuselage for best results. A transverse mounting on the bottom of the fuselage was shown to be the optimal location.

3. *Epoxy Torsion*

Testing immediately after curing resulted in a connection that we were unable to break by hand. After the connection had been fatigued with multiple tests over multiple days and the carbon fiber was cracked due to the compression of the pliers, the connection was able to be broken. The connection was never able to be broken by hand, which we estimate is a closer approximation of the possible torque that will be applied to the carbon rods.

4. *Wing Bending*

Maximum deflection as measured from the tip of the wings was found to be around 12 inches. Qualitatively, it was found that the top plywood layer deformed a lot, and may not be adequate to hold the solar panels. Due to the balsa reinforcements added later, there was more shear force on the ribs than initially designed for. A few of the ribs were shown to fail under a combination of torsion and bending.

5. *Drop Test*

No damage was observed for drop tests of any height up to 48 inches. No fracturing occurred in the carbon spars or fuselage. Electronics remained secure and connected during all drops.

6. *Panel Mounting*

When compared to the original values for voltage and current, it was determined there was negligible difference in efficiency. Next, the wing section with the panels was tested for durability by dropping it repeatedly on the table to simulate deflection during flight and force from landing. The results of this test for the fate of the solar panels was concerning because the panels broke in the test, which meant the wing likely would experience too much deflection for the panels to take during flight.

7. *Ease of Transport*

Dihedral connections were more difficult to remove than expected. One side took TIME to disassemble, and the other side was not possible to disassemble due to a stripped bolt. Disassembly of the wing from the fuselage took under 5 seconds. Due to part of the wing being unable to be disassembled, the length was larger than the given dimensions of a minivan. Despite this, all sections of the UAS were able to fit through a doorway and within a minivan for transport.

8. *Weight/Center of Gravity*

The UAS was within the 15 lbs limit, coming in at a total weight of (10.535 lbs), with the fuselage weighing 4.88 lbs, the tail weighing 1.01 lbs, and the wings weighing (10.535 lbs). After adjusting some of the components, the center of gravity was found to be slightly behind the location of the carbon spar (approximately 28 % of the chord), which is the ideal location for stable flight.

VI. Justification

A. Performance

While the mechanical aspects require further iteration and troubleshooting, the electrical circuit was completed and performed above expectations. The results above reveal that the aircraft could fly for approximately 3 hours on solely batter power, greatly exceeding the 15 minute performance expectation. As seen in the Finalized Circuit Test above, the circuit has the ability to charge batteries while running the motor at 1.5 lbs. of thrust, meaning that the aircraft would charge as long as the sun is out. This charging would greatly surpass the 8% loss in battery capacity. The wings were designed around the solar panel requirements, again meeting performance requirements.

B. Cost

A bill of materials (BOM) was kept up to date as purchases were made. From this we made sure to stay within the \$3000 budget. The final expenses for the project amounted to \$2961.43. While the team intended to have some headroom for redundancy, the iterative design process necessitated a few unintended purchases. The "big ticket items" include the Eflite 90 DC motor, Lectron 3S LiPo packs, Genasun GV-Boost charge controller, SunPower c60 solar cells, carbon fiber spars, balsa wood, and $\frac{1}{64}$ " plywood.

C. Weight

The UAS weight was verified through weighing the various sections and was determined to be well under the 15 lbs maximum that was set for the design.

D. Ease of Transport

We verified the size of the UAS by measuring each section and transporting the sections through doorways and by placing it into a small hatchback as seen in Figure 10. Additionally, the assembly can be completely put together in under 15 minutes upon arriving to an airfield. No component is too heavy or awkward to be carried by one person. With careful planning, the wing sections can be safely transported without additional packing or casing.

E. Aesthetics

The team and those close to the project agree that the plane looks very cool. The visible solar panels and electronics add interest to the plane. The carbon fiber fuselage is sleek and the blue/red dihedral sections add a nice touch of color. The fully assembled plane can be seen in Figure 11. In this image, the overall feel of the lift forces and center of gravity is being observed.

F. Safety

The circuit components are being used within their specifications which will minimize potential for fire. All exposed sharp surfaces were removed or sanded down on the UAS. The rotating components (motor and propeller) are



Figure 10: UAS shown in a small Hatchback

located in the front of the UAS and there is ample space between them and the place on the fuselage where it is to be held when hand-launched and thus should not pose a risk. All wiring is either super-glued or tied together with floss to prevent disconnection in flight. The wiring is kept within the UAS and has no exposed metal.

G. Durability

The drop test was used to verify the durability of the UAS. A full 6 foot drop test was not able to be conducted as of this report. As a test flight could not be scheduled, the stability in ideal weather was not able to be confirmed.

H. Maintenance

Maintenance was able to be made throughout the build process and the multiple assemblies and disassemblies that occurred during the semester. This is an area for future improvement, however, no destructive disassembly was required at any point in the build process.

I. Battery

Batteries were selected to be compatible with the maximum capable charge rate of a 50S array of SunPower c60 solar panels. Additionally, the batteries are fully compatible with all RC components, as was verified during all system testing. The thrust test particularly verified the feasibility of using these cells for this project. The batteries are a significant portion of the aircraft's total weight, however, this was necessary in order to maximize flight time and still provide the necessary thrust for flight.

J. Propulsion

The thrust testing that was conducted verified that the motor would be able to produce sufficient lift and maintain the proper cruising speed in flight with the given total weight and propeller. This testing also indicated that the peak efficiency was being achieved in the desired level flight power range.



Figure 11: Fully Assembled Plane

VII. Conclusions

At the time of this report, we have been unable to perform a flight test of any kind. This is largely due to an inability to ascertain proper insurance coverage for the flight in time, in accordance with Miami University regulations. The design is in compliance with FAA regulation and has been registered. As reported, major sub-assemblies were tested individually and feedback from experienced UAS pilots was incorporated into our final design. The circuit has been built, tested, and verified. In all of this are several key lessons.

A large concern with the wings is that they are not rigid enough to provide adequate support for the solar panels. The carbon fiber spar that was selected was determined based on a failure criteria with a given safety factor. It would have been more appropriate to determine what the maximum allowable deflection would be under loading to be able to support the solar panels. Once assembled, the wings bent up to a foot on either end under the static loading of the fuselage and electronic components' combined weight. With this much flexibility, the solar panels would have a high probability of fracture over time. In addition, this deflection could lead to some difficulty in steering as the ailerons bend with the wings.

Another related issue was that after the balsa leading and trailing edges as well as plywood components that ran the length of the wing were added, the wing was not able to flex as much. This distributed a lot of stress to the ribs that was not initially anticipated. Since the plywood skin is not as flexible as the carbon spar, that skin ended up taking a lot of the load and applying a shear force and bending moment onto the ribs.

A similar issue is the flexibility of the tail structure, as it is also connected using the same type of carbon fiber spar. This primarily could cause issues in the ability to control the UAS. When forces from the air are

applied to the tail's control surfaces in order to steer the aircraft, the carbon may not be rigid enough to translate these forces and instead deflect, rendering the steering useless. The current carbon spar could be modified to have a higher MOI by cutting an axial channel and epoxying an I-shaped carbon rod along the full length. The spar could also be replaced with an appropriately sized alternative. Adding a solid metal dowel inside the carbon would increase the bending stiffness but there is a major weight drawback.

Perfectly aligning the center of gravity of the UAS to the desired position proved difficult to do. In the end, even with the elongated fuselage, there was not enough variability in where components could be placed to move the CG far enough forward. This introduced inefficiencies in the aircraft as ballast weights need added to the aircraft in order to balance the center of gravity. In retrospect, adjust-ability in locating the connection of the wing onto the fuselage may have prevented this problem, as the center of gravity could be adjusted with the center of lift. Generally, improvements to ease of assembly could be made.

There was much learned in regards to circuitry and solar panel integration. The circuit was built from the ground up, with initial assumptions concerning weight and wingspan directing the construction of the aircraft. The solar panels were effectively identified, constructed, and tested. The necessary circuitry to regulate this input was identified and purchased in the form of a custom Genasun GV-Boost charge controller. The circuit components for RC flight were identified based off of these assumptions and an aircraft was designed to utilize them most efficiently. A battery system and complementary balancing board were also identified and all of these components were combined harmoniously to create a working electrical system. All of this was performed by a group of mechanical engineers with minimal exposure to electrical systems.

Along with these lessons learned were many successes throughout the project. Each section was fully designed, modeled, planned, and manufactured. The sections were able to come together to form the full UAS with a reasonably close center of gravity. All mechanical aspects were able to withstand the loading that they were designed for without failure. In addition, the circuit performed correctly outside of the plane as a proof of concept for operation in flight. The experience of managing a year long project has improved the leadership and work ethic of all six team members.

VIII. Future Work

If progress was continued on this project, there are a number of improvements that could be made. In order to have stable, controllable flight, wires could be used to connect the two dihedral connections below the fuselage and the tail to the fuselage. This would create an opposing force to reduce deflection. It may also be possible to add an additional flat panel or square piece of carbon fiber next to the main spar by cutting in or removing portions of the ribs to increase the moment of inertia, again reducing deflection. Floss can be tied to the servo connecting wires in places where the UAS is meant to be disassembled to ensure they do not come unplugged in flight. A square carbon fiber tube can be adhered to the tail-to-fuselage rod to increase stiffness and decrease deflection. Weight can be added to the front portion of the fuselage to move the center of gravity to the location of the wing spar. Slots could be cut into the plywood top of the wing to allow for deflection without deforming the solar panels to the point of fracture.

The project could also be taken in new directions if it were to continue with a new group of students. Examples of new projects could include improving the overall mechanical design of the airframe, making the UAS able to be controlled through programming rather than a controller, or increasing the charge capabilities through the circuit design.

A group of electrical engineering students would be able to create a single circuit board to replace the charge controller and battery balancing boards with a single component. This would reduce the weight of the electrical system and allow for the board to be customized for the specific motor, panel, and battery configuration of this system. Another project would be implementing GPS navigation and programming a surveillance system to meet Butler Rural Electric Cooperative's goal of utilizing this UAS to survey their right of ways.

IX. Acknowledgments

We would like to thank the following individuals for their invaluable contributions to our project:

Dr. Fazeel Khan for sharing his expertise with RC airplanes and mechanical design, Dr. Mark Scott for expert knowledge with circuitry and electrical engineering, Nick Brown for being our advisor and providing project advice and manufacturing knowledge, Christy Heinrich for placing all of our orders expediently, Prof.

John Richter for advising the project, Ryan Gilley from Genasun for his expertise on charge controllers, and Bob Dochterman for contributing his time and piloting skills at the HAWKS airfield

We express our deepest gratitude to Butler Rural Electric Cooperative for funding this project, without whom we could not have done such an ambitious, fun project. Also, we express our thanks to the people at Hamilton Hobbies who have assisted the team in their endeavors. Finally, thank you to the Miami University Mechanical Engineering Department for funding and overseeing the MME senior design projects.

References

- ¹AG35 - Drela AG35 airfoil. Retrieved September, 2016, from <http://airfoiltools.com/airfoil/details?airfoil=ag35-il>
- ²Cargo Drone Challenge, *Local Motors Unmanned Aircraft Design Guide*, Airbus Group, n.d.
- ³Carnegie, Claudius, *Stability of an Airplane - Level 3*, ALLSTAR Network, May 2008.
- ⁴Dieter, George E., Schmidt, Linda C., *Engineering Design*, Fourth Edition, McGraw-Hill Higher Education, New York, 2009.
- ⁵Duncan, John S. *Advisory Circular: Small Unmanned Aircraft Systems (sUAS)*, U.S. Department of Transportation, Federal Aviation Administration, 2016.
- ⁶*Everything you Need to Know About the Basics of Solar Charge Controllers*, Northern Arizona Wind & Sun, 2017.
- ⁷How to calculate Power Required At Takeoff. (2014, February 23). Retrieved September, 2016, from <https://www.rcgroups.com/forums/showthread.php?2110765-How-to-calculate-Power-Required-At-Takeoff>
- ⁸Malyuta, Daniel, *How to Design your own R/C Aircraft guide: Part 2 (Designing the Tail)*, Malyuta Avionics, n.d.
- ⁹Oettershagen, Philipp, *A Solar-Powered Hand-Launchable UAV for Low-Altitude Multi-Day*, Autonomous Systems Lab, Swiss Federal Institute of Technology Zurich, Zurich, 2016.
- ¹⁰Oettershagen, Philipp, *Perpetual flight with a small solar-powered UAV: Flight results, performance analysis and model validation*, Autonomous Systems Lab, Swiss Federal Institute of Technology Zurich, Zurich, 2016.
- ¹¹Sadraey, Mohammad, *Design of Control Surfaces: Chapter 12: Elevator Design*, Wiley Publications, September 2012.
- ¹²Schneider, Brain, *A Guide to Understanding LiPo Batteries*, Roger's Hobby Center, Saginaw, MI, March 2017.
- ¹³Weider, A. *SunSailor: Solar Powered UAV*, Faculty of Aerospace Engineering, Technion IIT, Haifa, Israel, 2006.

Appendix A Mechanical Drawing Package

A Series	Assemblies
C Series	Center Section
D Series	Dihedral Section
E Series	Electronics
T Series	Tail Section

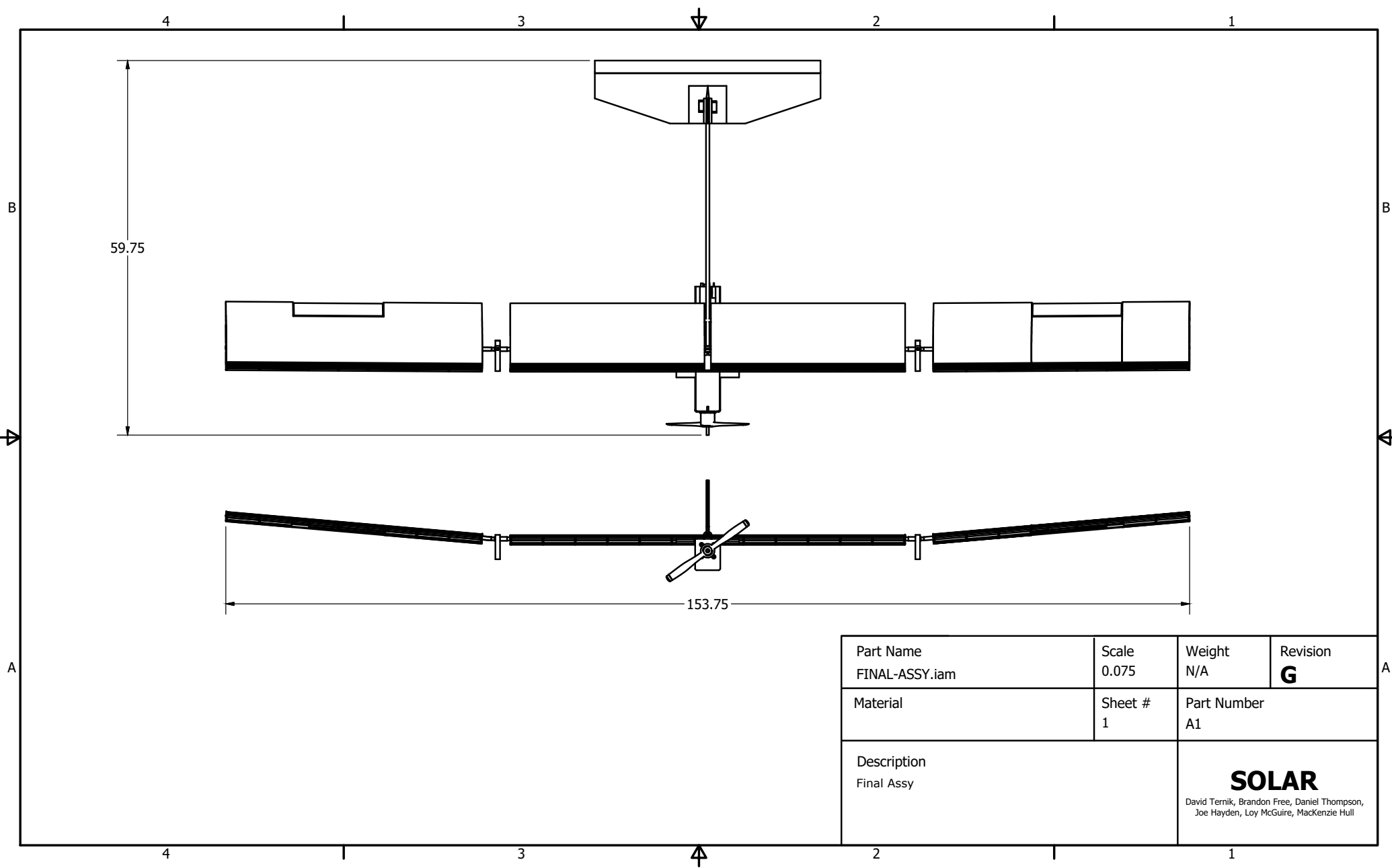

Part Name FINAL-ASSY.iam	Scale 0.075	Weight N/A	Revision G
Material	Sheet # 1	Part Number A1	
Description Final Assy		<p align="center">SOLAR</p> <small>David Ternik, Brandon Free, Daniel Thompson, Joe Hayden, Loy McGuire, MacKenzie Hull</small>	

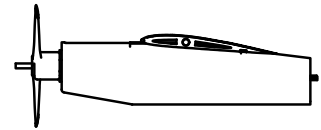
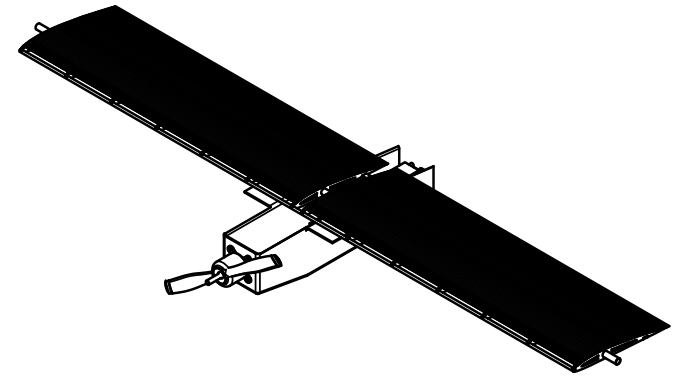
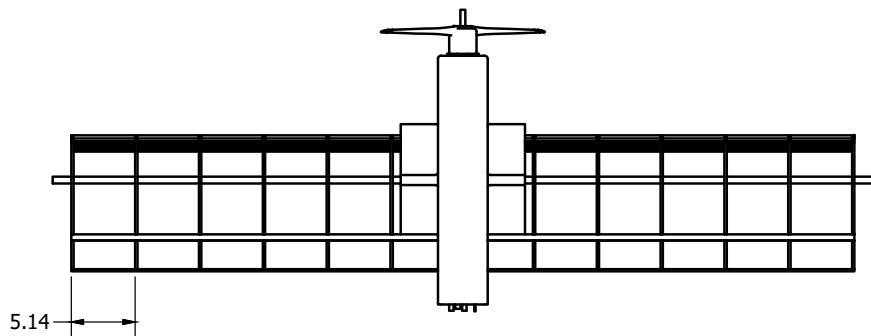
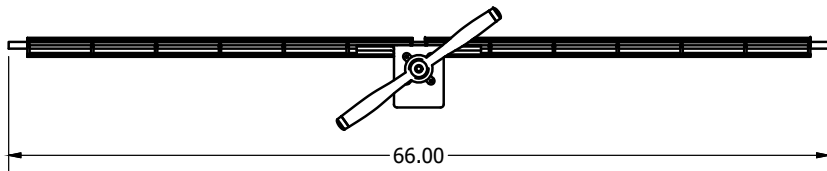
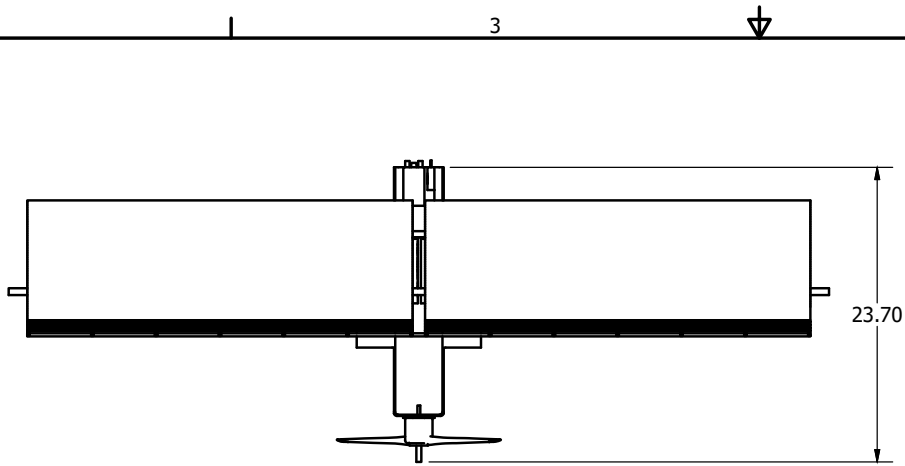

Part Name CENTER-MAIN-ASSY.iam	Scale 0.1	Weight 6.507 lbmass	Revision G
Material	Sheet # 2	Part Number A2	
Description Center Section Assembly		<p align="center">SOLAR</p> <small>David Ternik, Brandon Free, Daniel Thompson, Joe Hayden, Loy McGuire, MacKenzie Hull</small>	

4

3

2

1

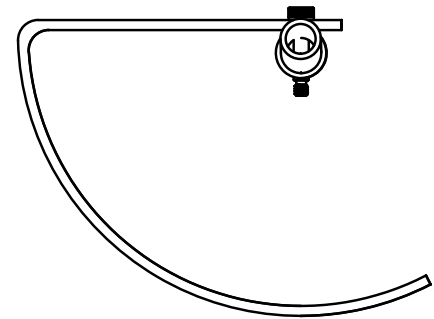
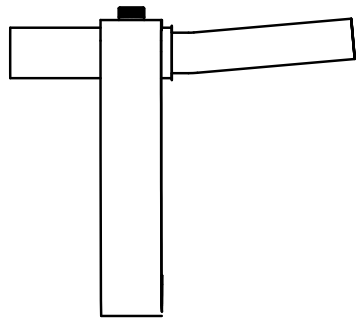
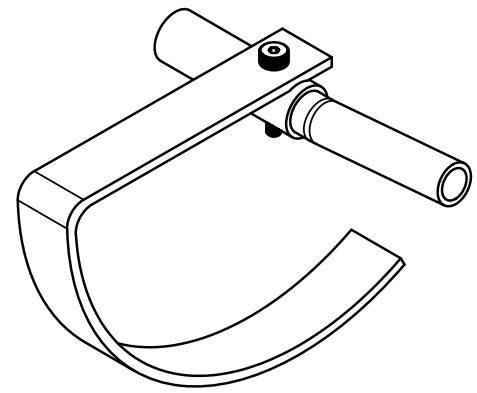
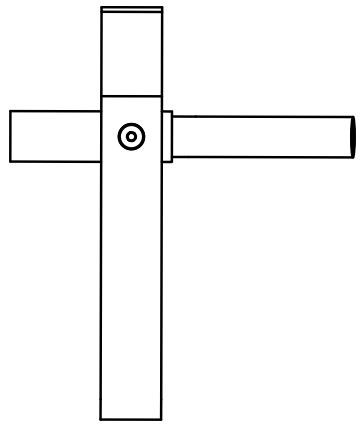

B

B

A

A

A

A

4

3

2

1

Part Name DIHEDRAL-CONNECTION.iam	Scale 0.65	Weight N/A	Revision G
Material	Sheet # 3	Part Number A3	
Description Dihedral Connection Assembly		<p align="center">SOLAR</p> <small>David Ternik, Brandon Free, Daniel Thompson, Joe Hayden, Loy McGuire, MacKenzie Hull</small>	

4

3

2

1

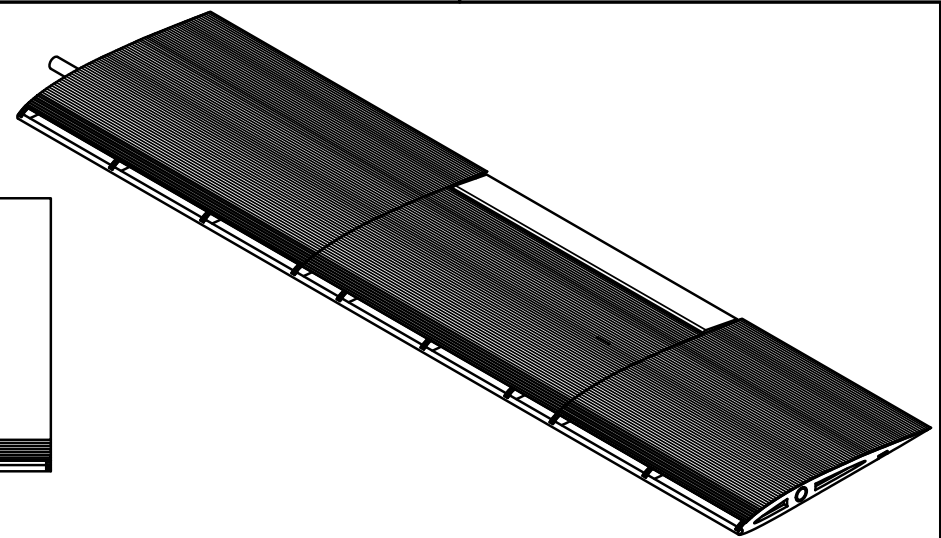

B

B

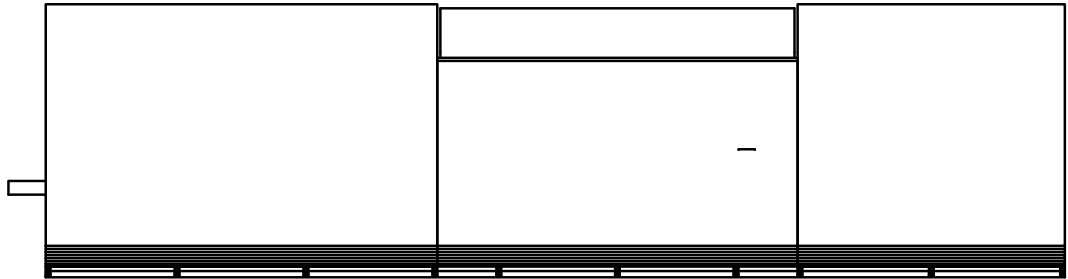

A

A

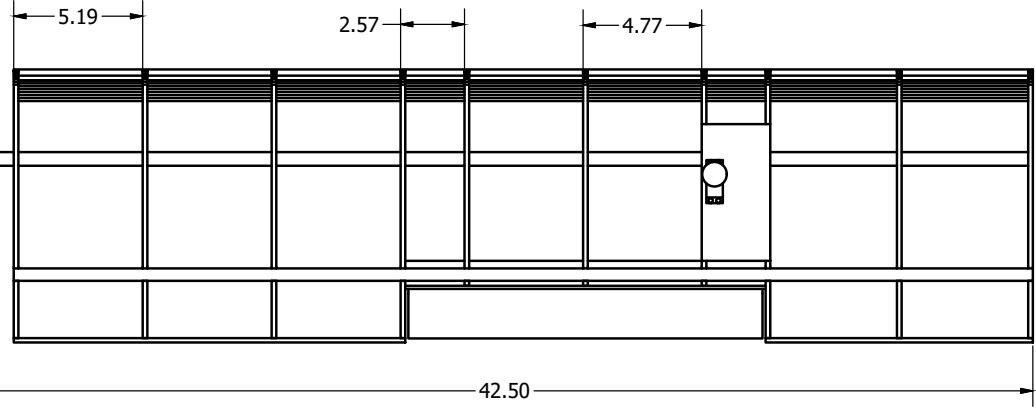

4

3

2

1

Part Name DIHEDRAL-MAIN-ASSY.iam	Scale 0.2	Weight N/A	Revision G
Material	Sheet # 4	Part Number A4	
Description Dihedral Assembly		SOLAR David Ternik, Brandon Free, Daniel Thompson, Joe Hayden, Loy McGuire, MacKenzie Hull	

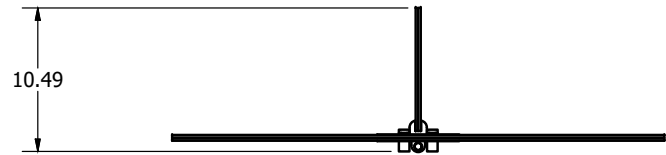
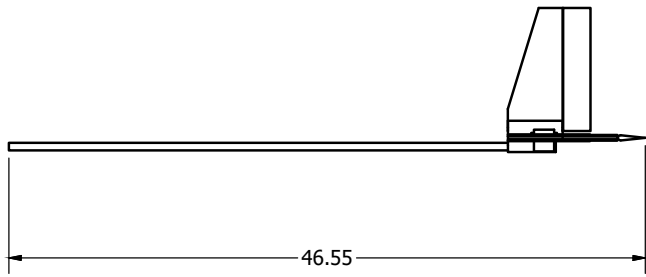
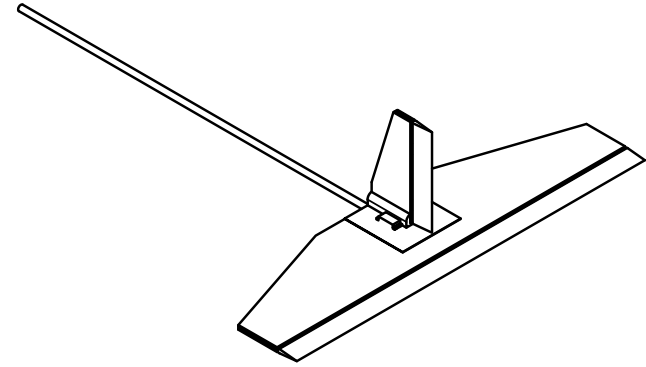
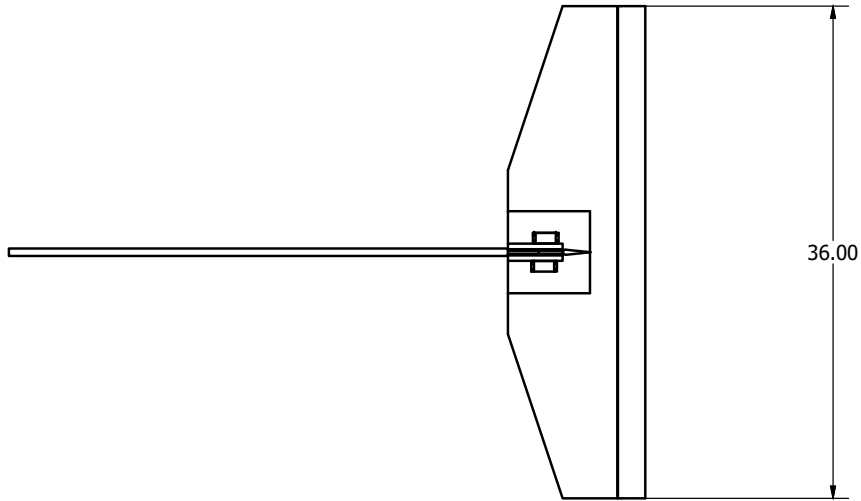

Part Name TAIL-ASSY.iam	Scale 0.11 : 1	Weight 1.162 lbmass	Revision G
Material	Sheet # 5	Part Number A5	
Description Tail Assembly		<p align="center">SOLAR</p> <small>David Ternik, Brandon Free, Daniel Thompson, Joe Hayden, Loy McGuire, MacKenzie Hull</small>	

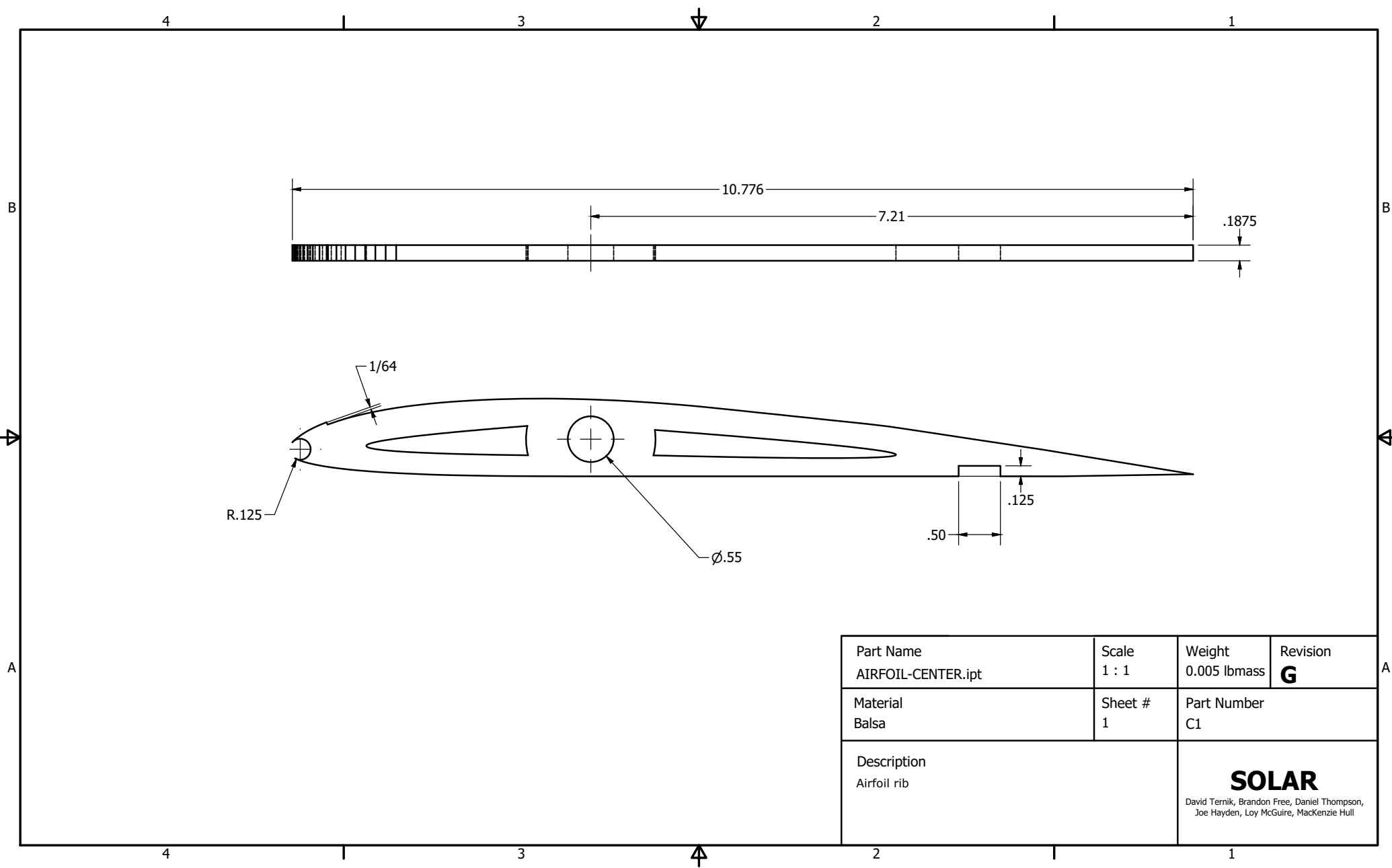

Part Name AIRFOIL-CENTER.ipt	Scale 1 : 1	Weight 0.005 lbmass	Revision G
Material Balsa	Sheet # 1	Part Number C1	
Description Airfoil rib		SOLAR <small>David Ternik, Brandon Free, Daniel Thompson, Joe Hayden, Loy McGuire, MacKenzie Hull</small>	

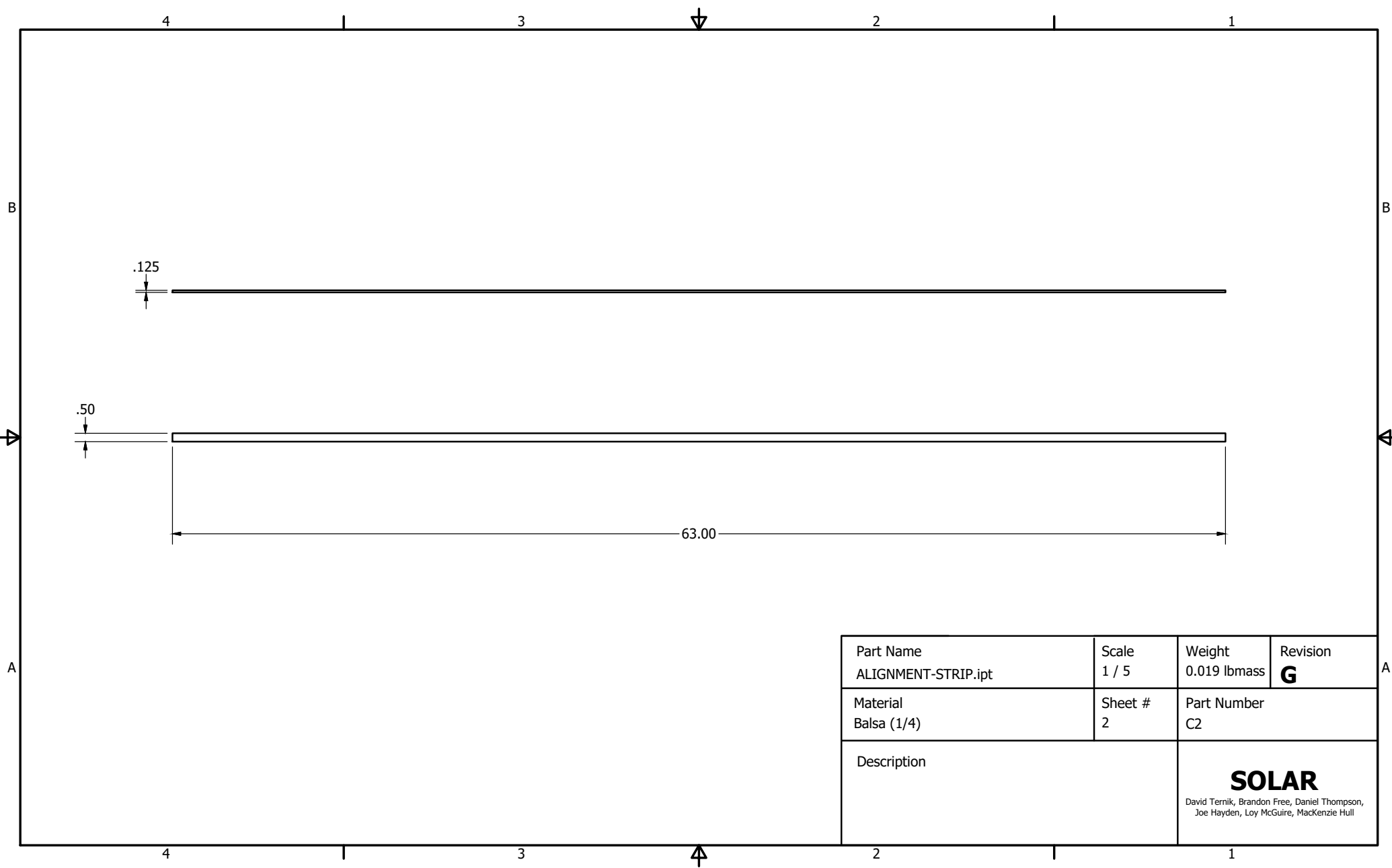

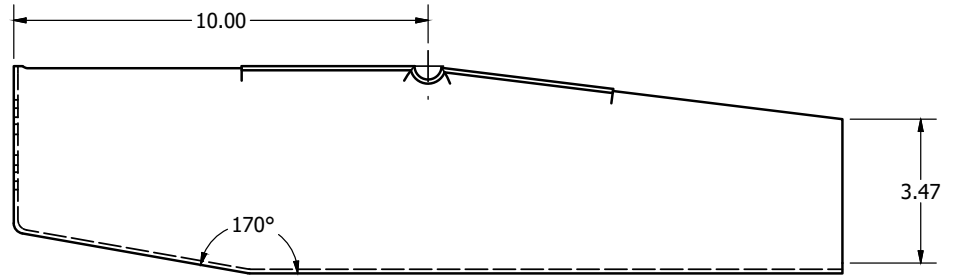
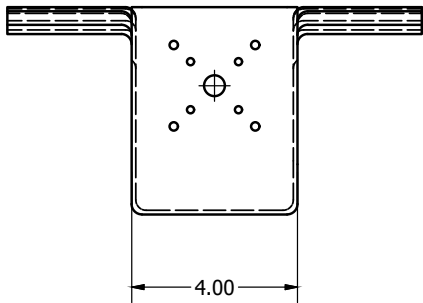
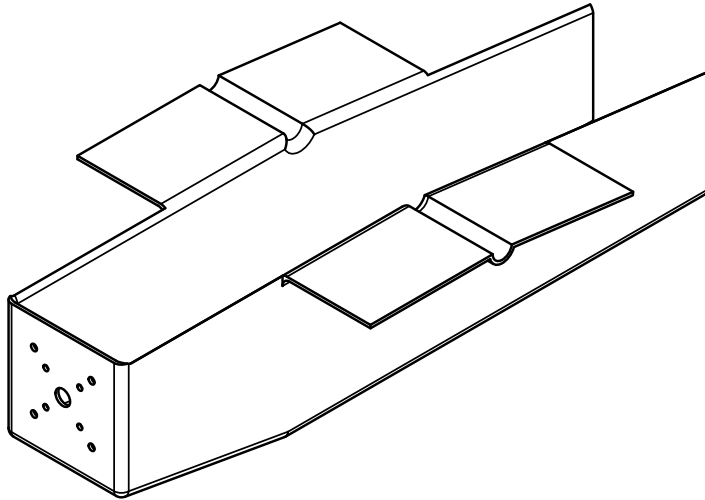

Part Name FUSELAGE.ipt	Scale 1 / 3	Weight 2.085 lbmass	Revision G
Material Carbon Fiber T300	Sheet # 3	Part Number C3	
Description		SOLAR David Ternik, Brandon Free, Daniel Thompson, Joe Hayden, Loy McGuire, MacKenzie Hull	

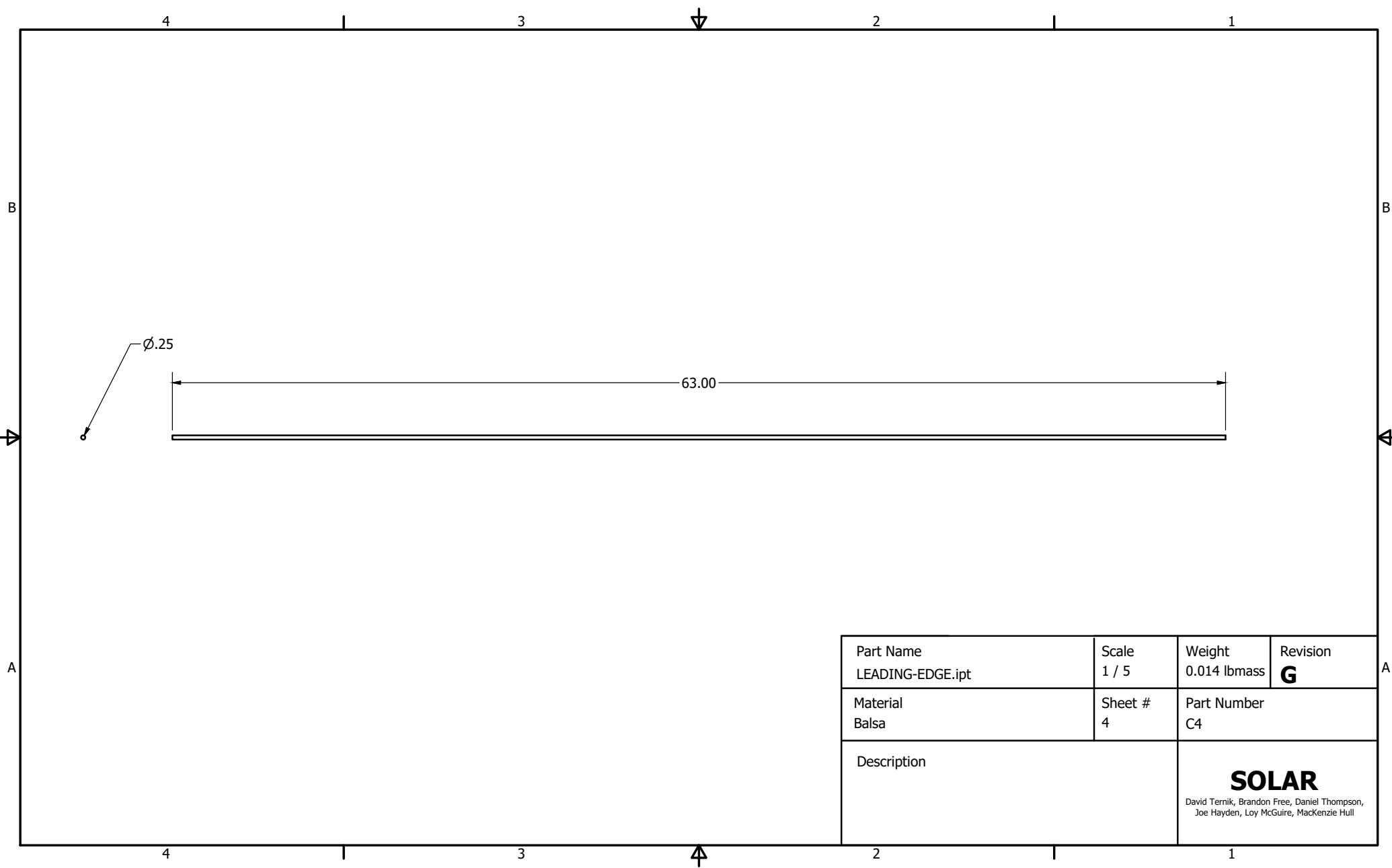

Part Name LEADING-EDGE.ipt	Scale 1 / 5	Weight 0.014 lbmass	Revision G
Material Balsa	Sheet # 4	Part Number C4	
Description		<p align="center">SOLAR</p> <p align="center">David Ternik, Brandon Free, Daniel Thompson, Joe Hayden, Loy McGuire, MacKenzie Hull</p>	

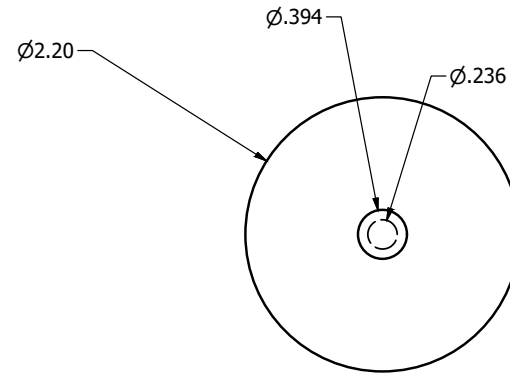
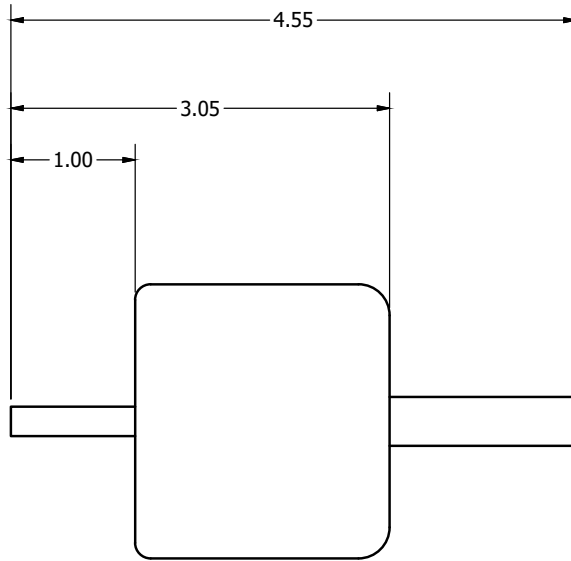

Part Name MOTOR-EFLITE_POWER_90.ipt	Scale 1 : 1	Weight 0.987 lbmass	Revision G
Material E Flite Power 90 Motor	Sheet # 5	Part Number C5	
Description		<p align="center">SOLAR</p> <p align="center">David Ternik, Brandon Free, Daniel Thompson, Joe Hayden, Loy McGuire, MacKenzie Hull</p>	

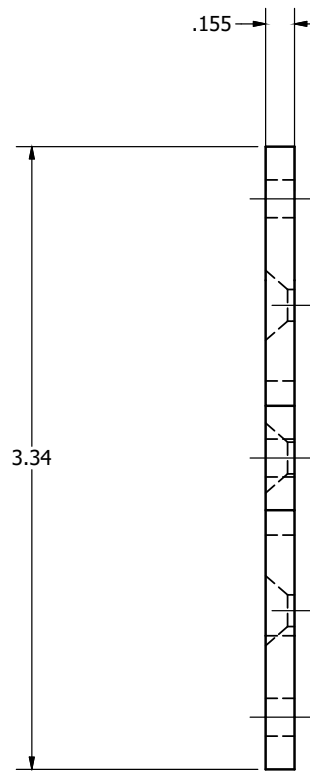
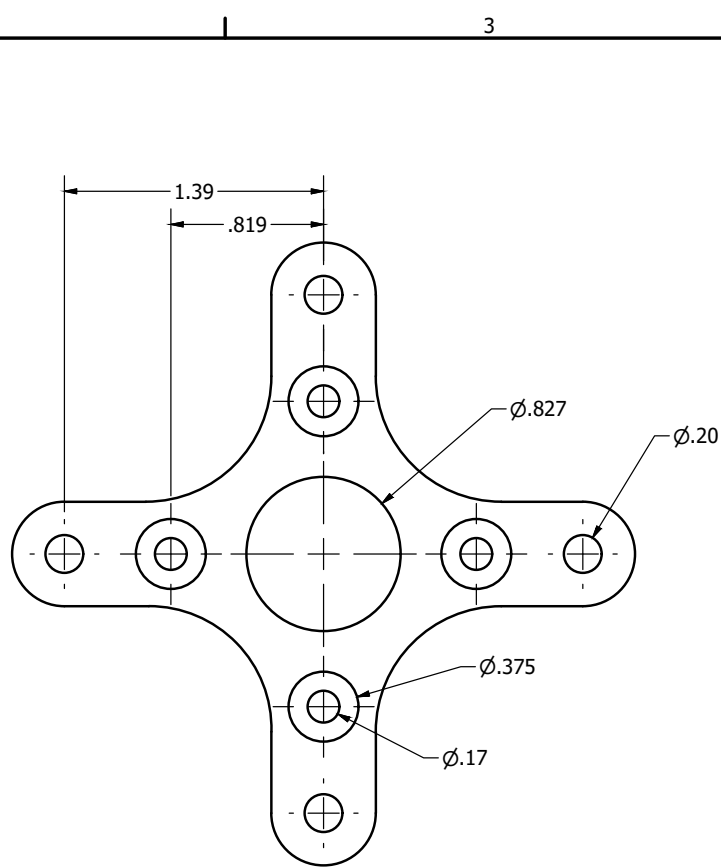

Part Name MOTOR-MOUNT.ipt	Scale 1.5 : 1	Weight 0.123 lbmass	Revision G
Material Steel	Sheet # 6	Part Number C6	
Description		<p align="center">SOLAR</p> <p align="center">David Ternik, Brandon Free, Daniel Thompson, Joe Hayden, Loy McGuire, MacKenzie Hull</p>	

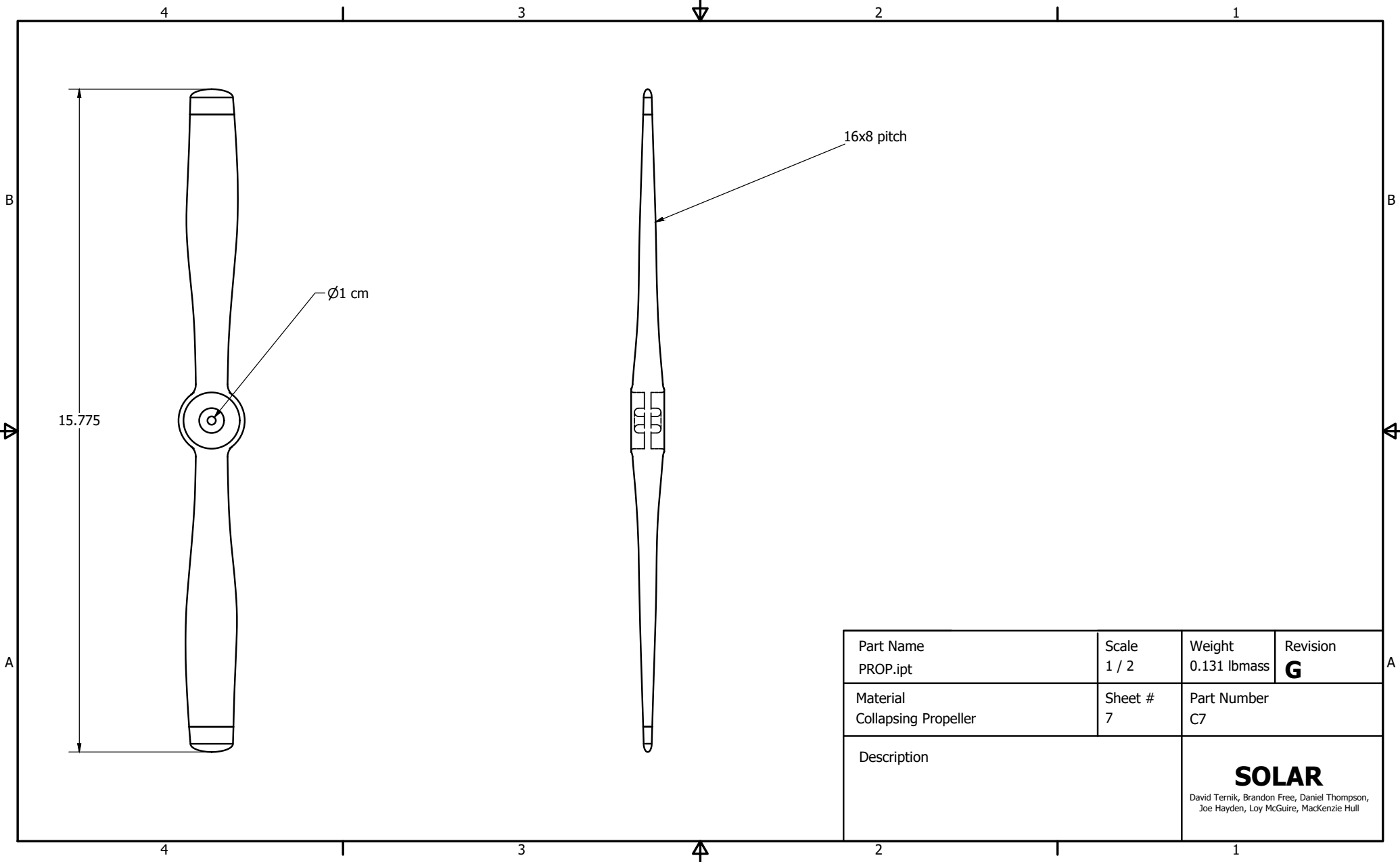

Part Name PROP.ipt	Scale 1 / 2	Weight 0.131 lbmass	Revision G
Material Collapsing Propeller	Sheet # 7	Part Number C7	
Description		<p align="center">SOLAR</p> <p align="center">David Ternik, Brandon Free, Daniel Thompson, Joe Hayden, Loy McGuire, MacKenzie Hull</p>	

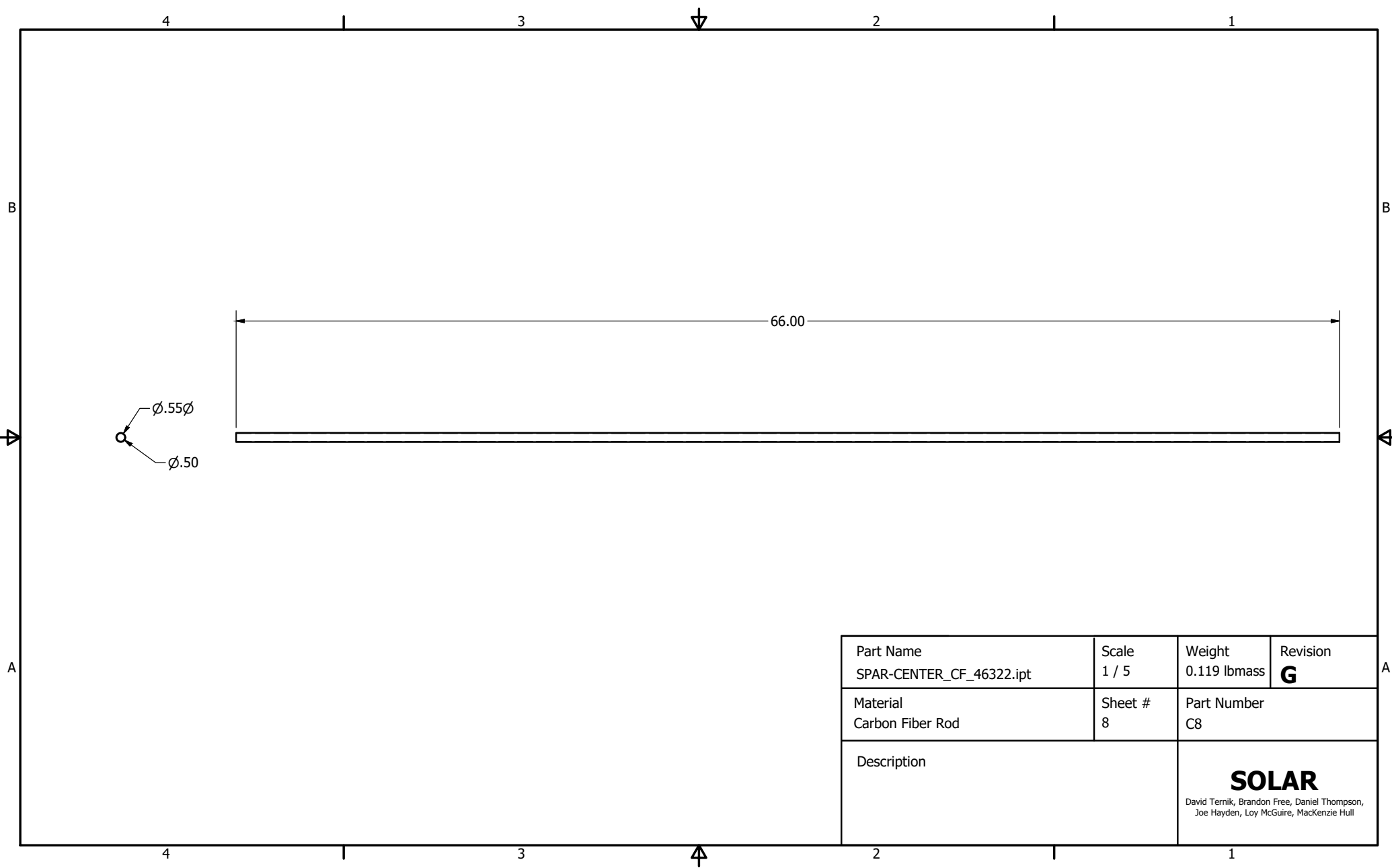

Part Name SPAR-CENTER_CF_46322.ipt	Scale 1 / 5	Weight 0.119 lbmass	Revision G
Material Carbon Fiber Rod	Sheet # 8	Part Number C8	
Description		<p align="center">SOLAR</p> <p align="center">David Ternik, Brandon Free, Daniel Thompson, Joe Hayden, Loy McGuire, MacKenzie Hull</p>	

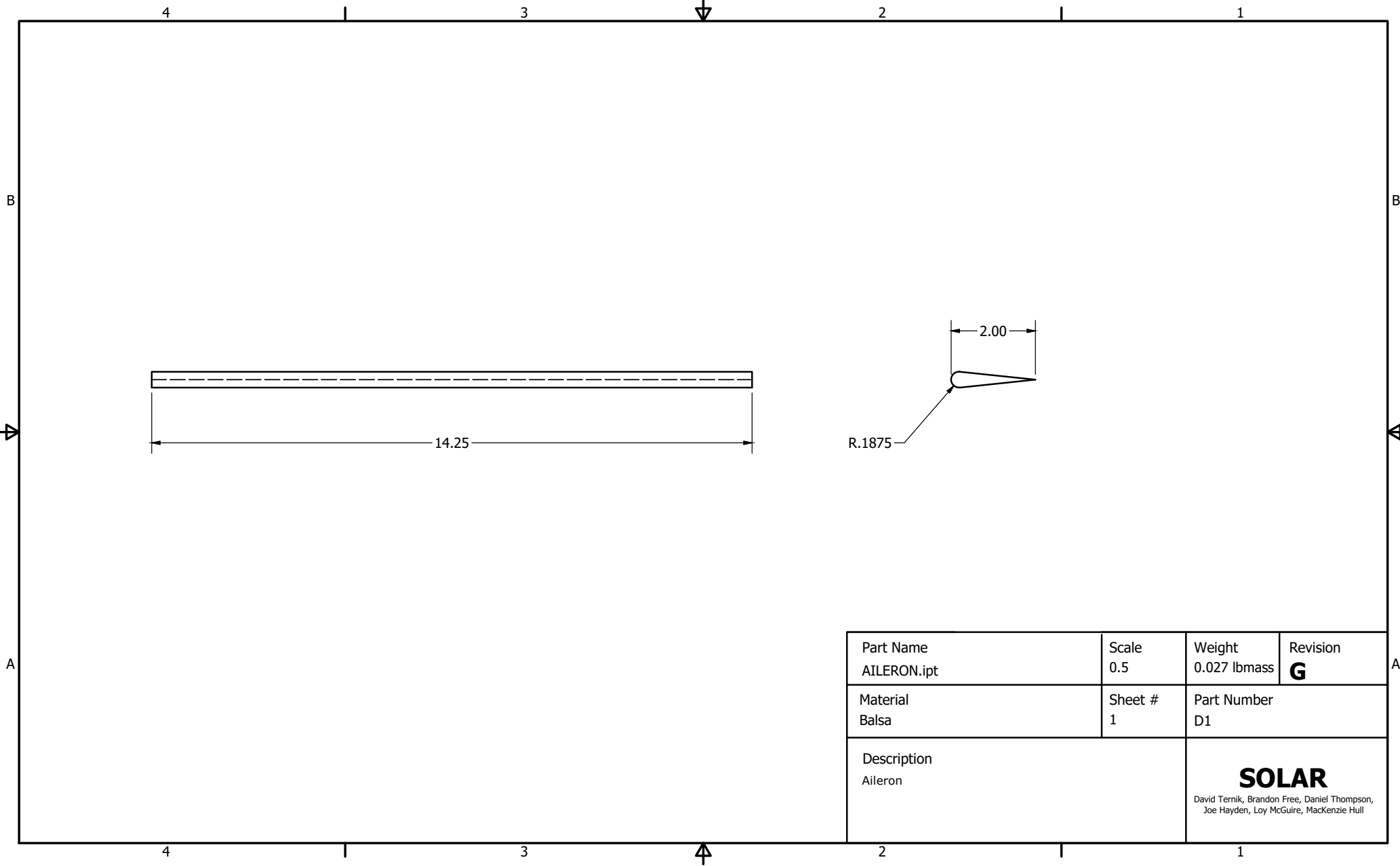

Part Name AILERON.ipt	Scale 0.5	Weight 0.027 lbmass	Revision G
Material Balsa	Sheet # 1	Part Number D1	
Description Aileron		<p align="center">SOLAR</p> <small>David Ternik, Brandon Free, Daniel Thompson, Joe Hayden, Loy McGuire, MacKenzie Hull</small>	

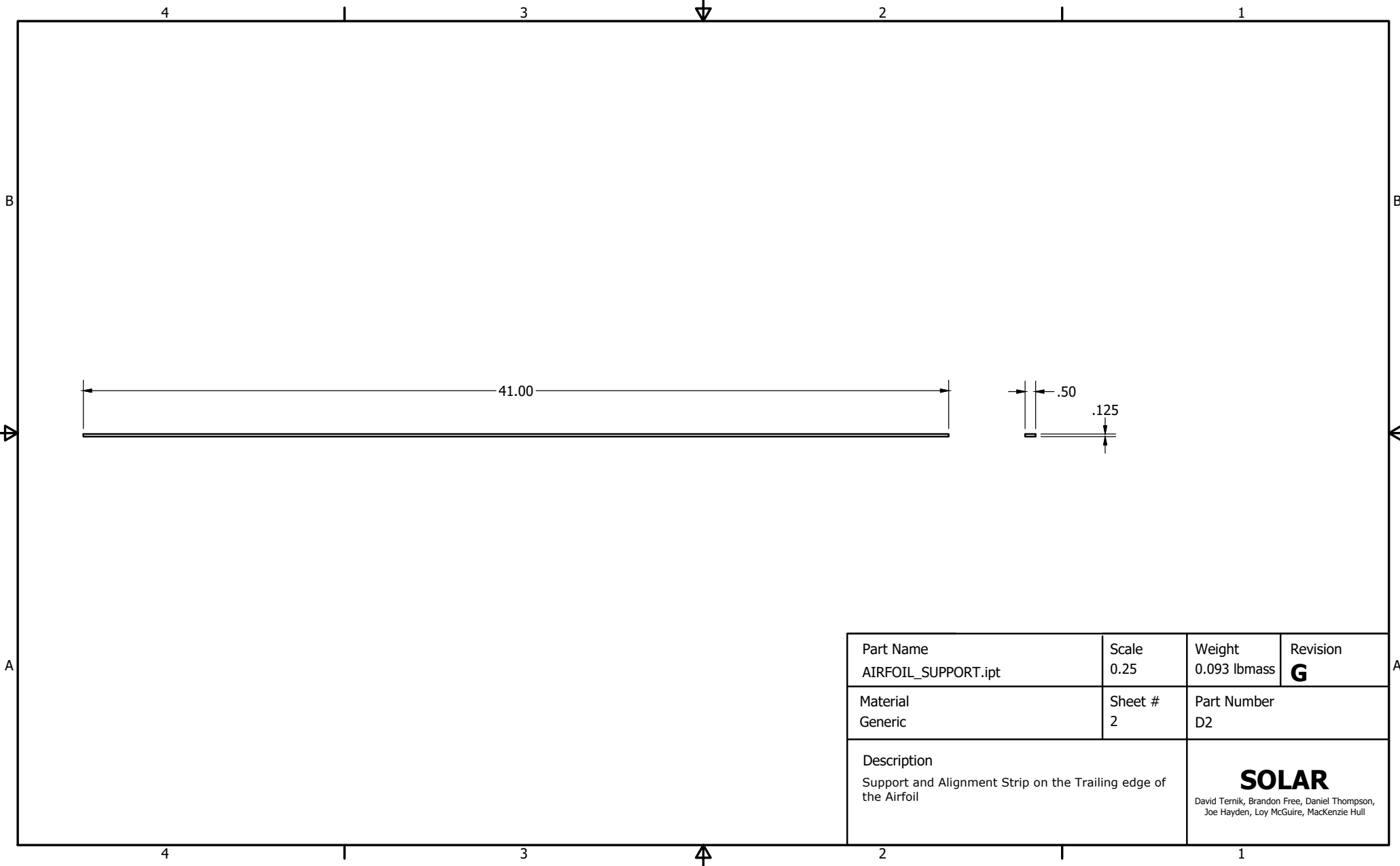

Part Name AIRFOIL_SUPPORT.ipt	Scale 0.25	Weight 0.093 lbmass	Revision G
Material Generic	Sheet # 2	Part Number D2	
Description Support and Alignment Strip on the Trailing edge of the Airfoil		SOLAR <small>David Ternik, Brandon Free, Daniel Thompson, Joe Hayden, Loy McGuire, MacKenzie Hull</small>	

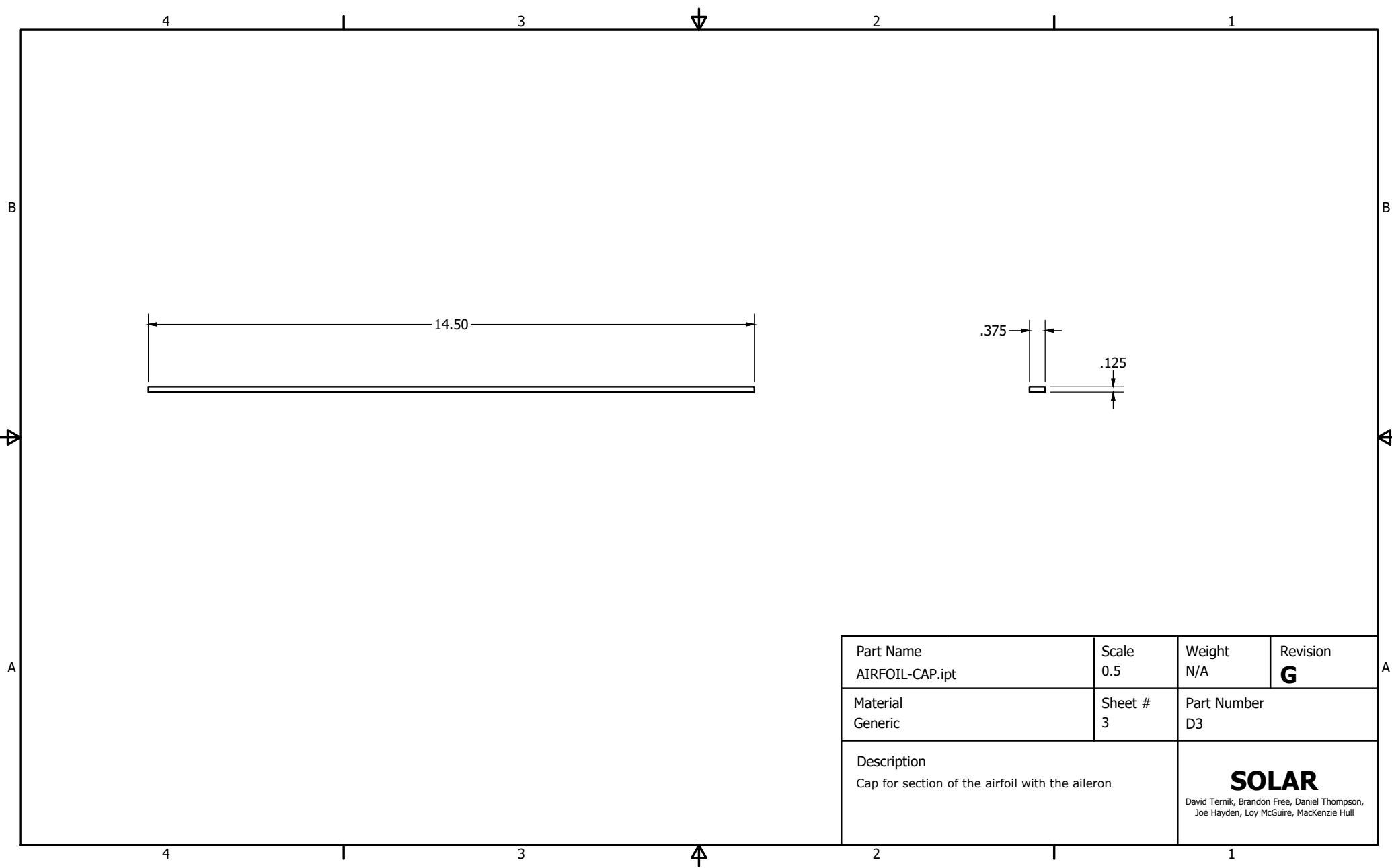

Part Name AIRFOIL-CAP.ipt	Scale 0.5	Weight N/A	Revision G
Material Generic	Sheet # 3	Part Number D3	
Description Cap for section of the airfoil with the aileron		SOLAR <small>David Ternik, Brandon Free, Daniel Thompson, Joe Hayden, Loy McGuire, MacKenzie Hull</small>	

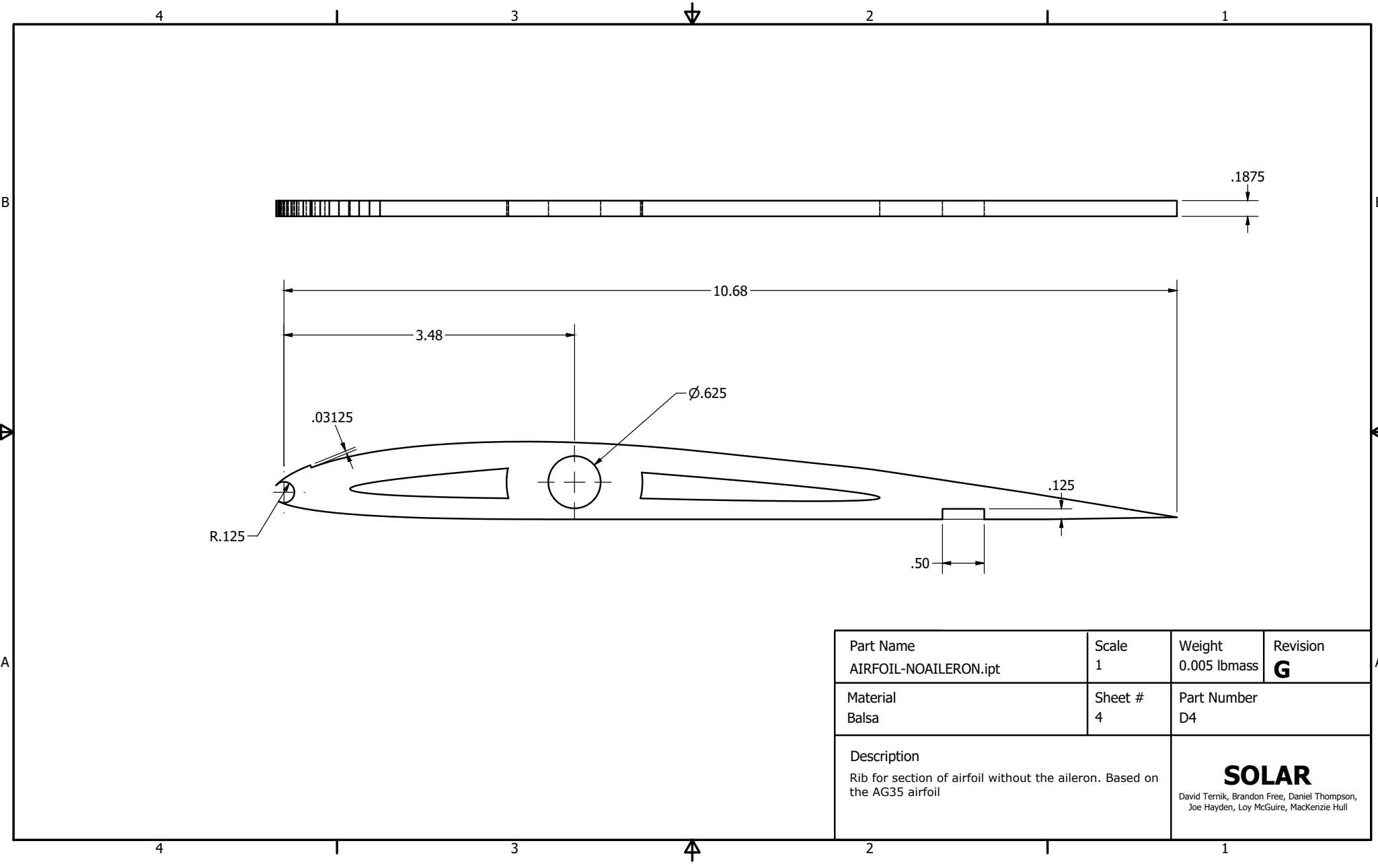

Part Name AIRFOIL-NOAILERON.ipt	Scale 1	Weight 0.005 lbmass	Revision G
Material Balsa	Sheet # 4	Part Number D4	
Description Rib for section of airfoil without the aileron. Based on the AG35 airfoil		SOLAR David Ternik, Brandon Free, Daniel Thompson, Joe Hayden, Loy McGuire, MacKenzie Hull	

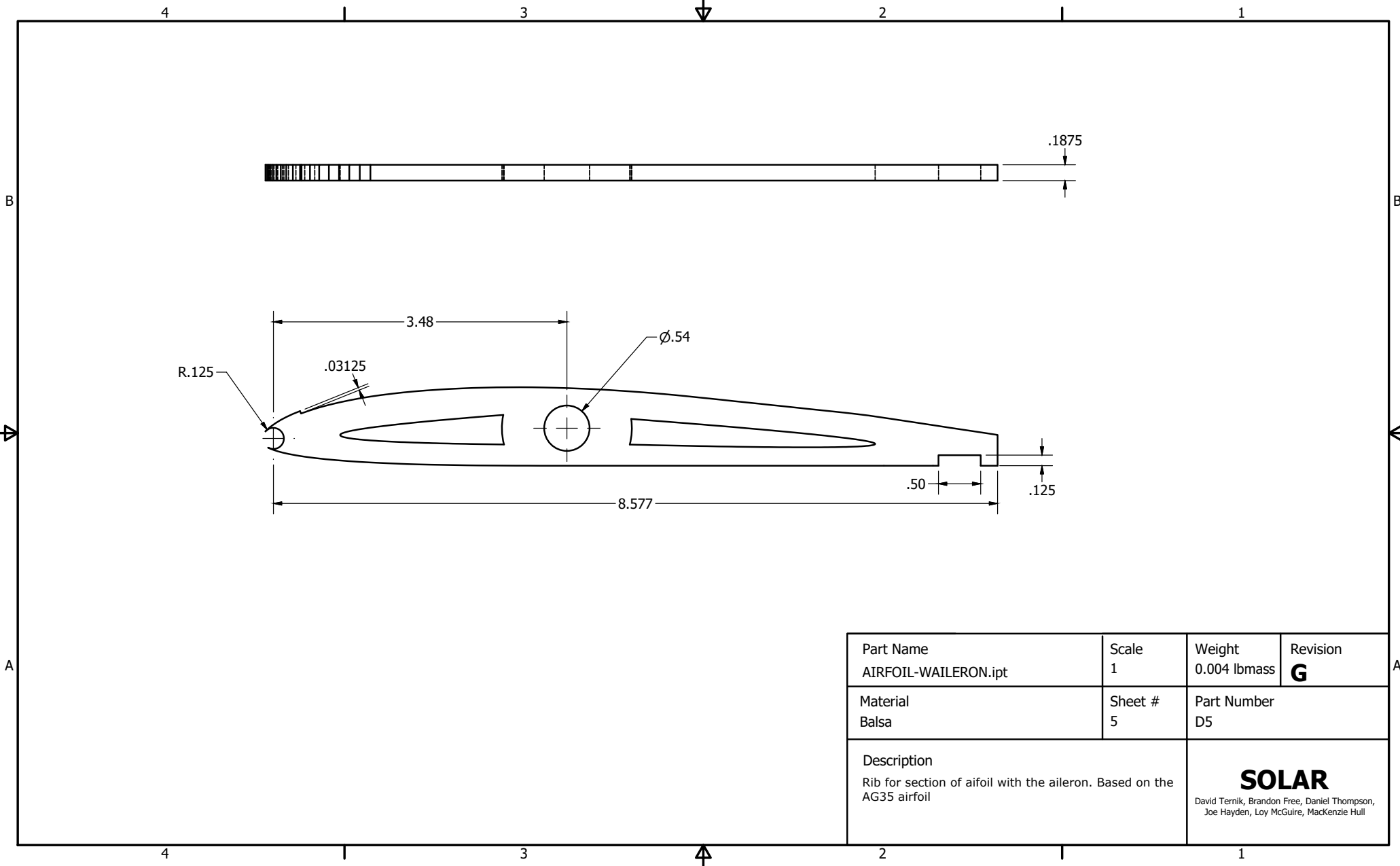

Part Name AIRFOIL-WAILERON.ipt	Scale 1	Weight 0.004 lbmass	Revision G
Material Balsa	Sheet # 5	Part Number D5	
Description Rib for section of airfoil with the aileron. Based on the AG35 airfoil		SOLAR <small>David Ternik, Brandon Free, Daniel Thompson, Joe Hayden, Loy McGuire, MacKenzie Hull</small>	

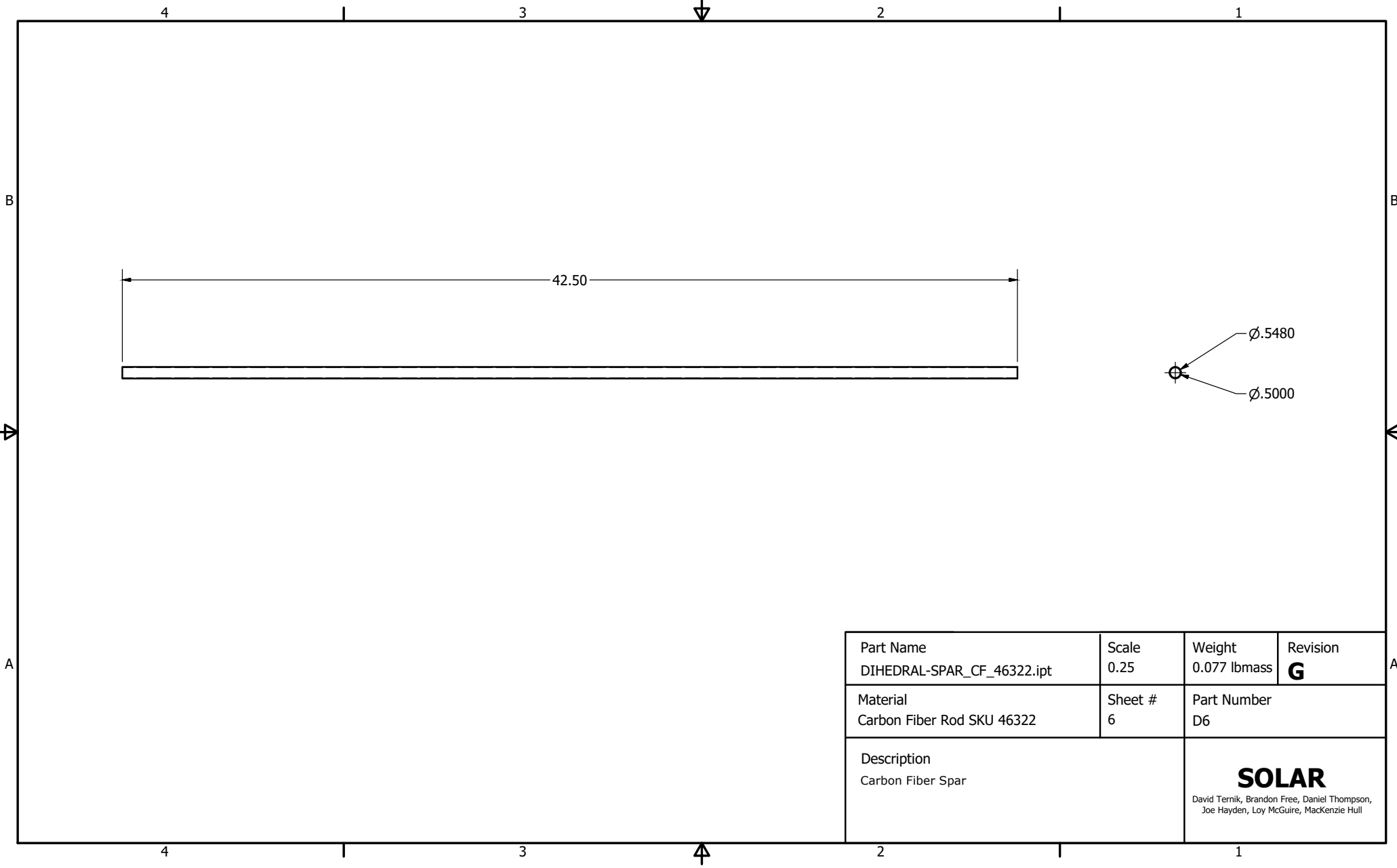

Part Name DIHEDRAL-SPAR_CF_46322.ipt	Scale 0.25	Weight 0.077 lbmass	Revision G
Material Carbon Fiber Rod SKU 46322	Sheet # 6	Part Number D6	
Description Carbon Fiber Spar		<p align="center">SOLAR</p> <small>David Ternik, Brandon Free, Daniel Thompson, Joe Hayden, Loy McGuire, MacKenzie Hull</small>	

4

3

2

1

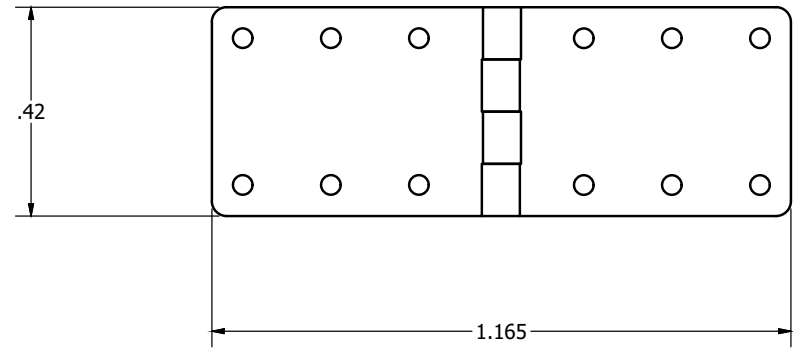
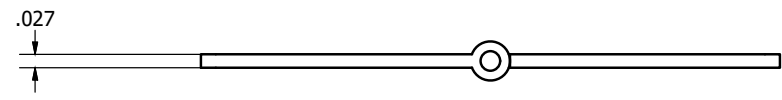

B

B

A

A

4

3

2

1

Part Name HINGE-ASSY.iam	Scale 4 : 1	Weight 0.001 lbmass	Revision G
Material	Sheet # 7	Part Number D7	
Description Hinge Assembly		<p align="center">SOLAR</p> <small>David Ternik, Brandon Free, Daniel Thompson, Joe Hayden, Loy McGuire, MacKenzie Hull</small>	

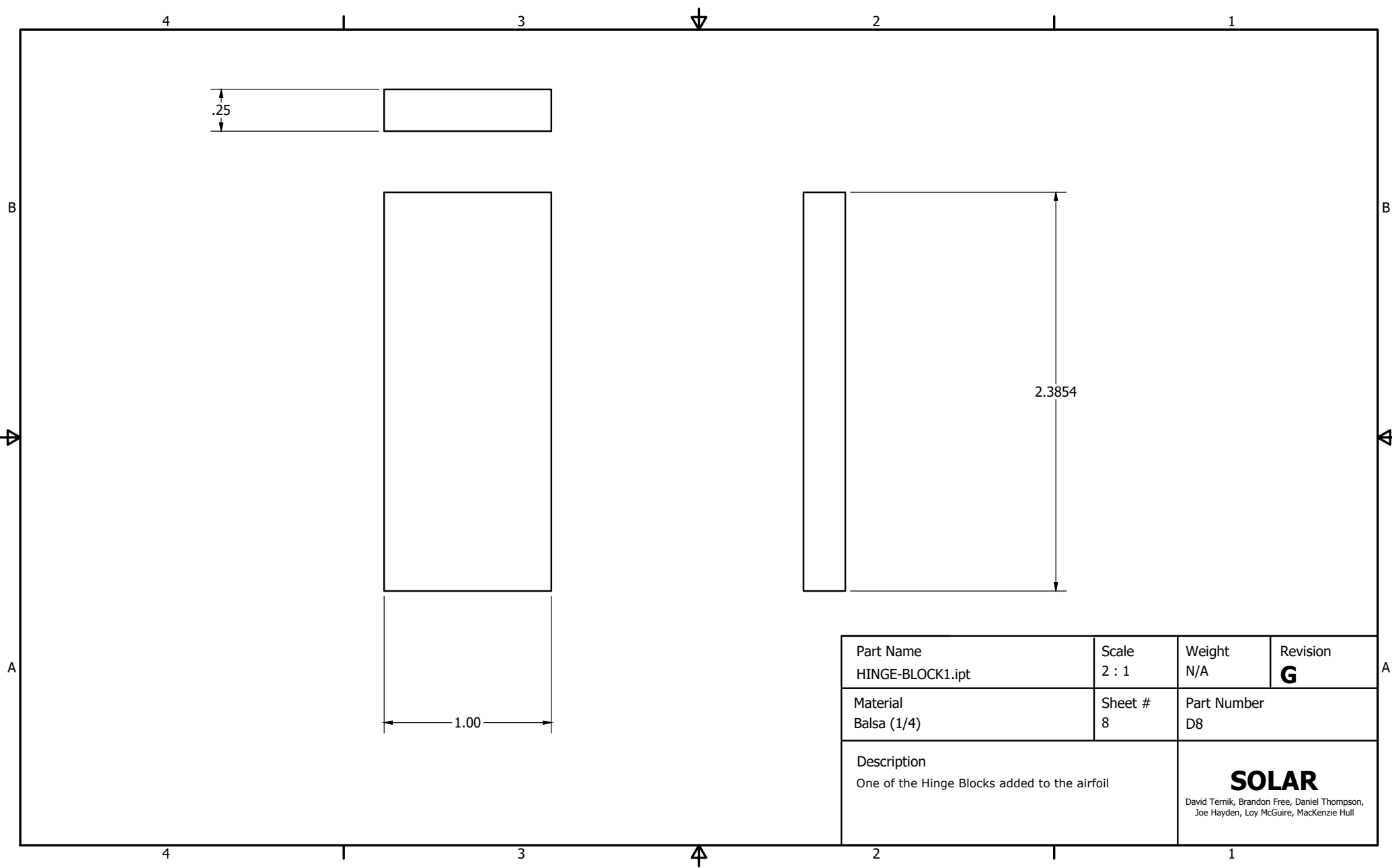

Part Name HINGE-BLOCK1.ipt	Scale 2 : 1	Weight N/A	Revision G
Material Balsa (1/4)	Sheet # 8	Part Number D8	
Description One of the Hinge Blocks added to the airfoil		<p align="center">SOLAR</p> <small>David Ternik, Brandon Free, Daniel Thompson, Joe Hayden, Loy McGuire, MacKenzie Hull</small>	

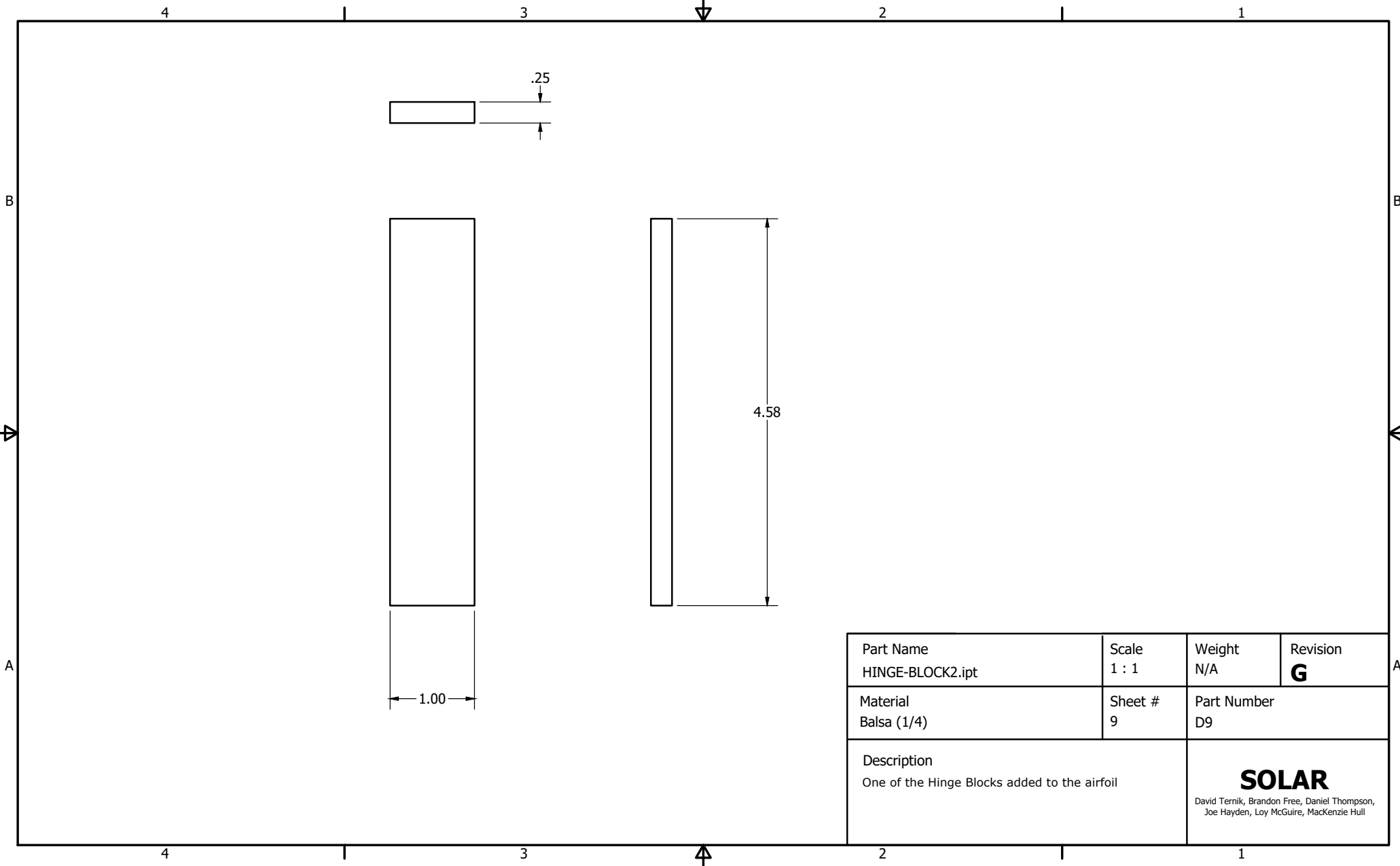

Part Name HINGE-BLOCK2.ipt	Scale 1 : 1	Weight N/A	Revision G
Material Balsa (1/4)	Sheet # 9	Part Number D9	
Description One of the Hinge Blocks added to the airfoil		<p align="center">SOLAR</p> <small>David Ternik, Brandon Free, Daniel Thompson, Joe Hayden, Loy McGuire, MacKenzie Hull</small>	

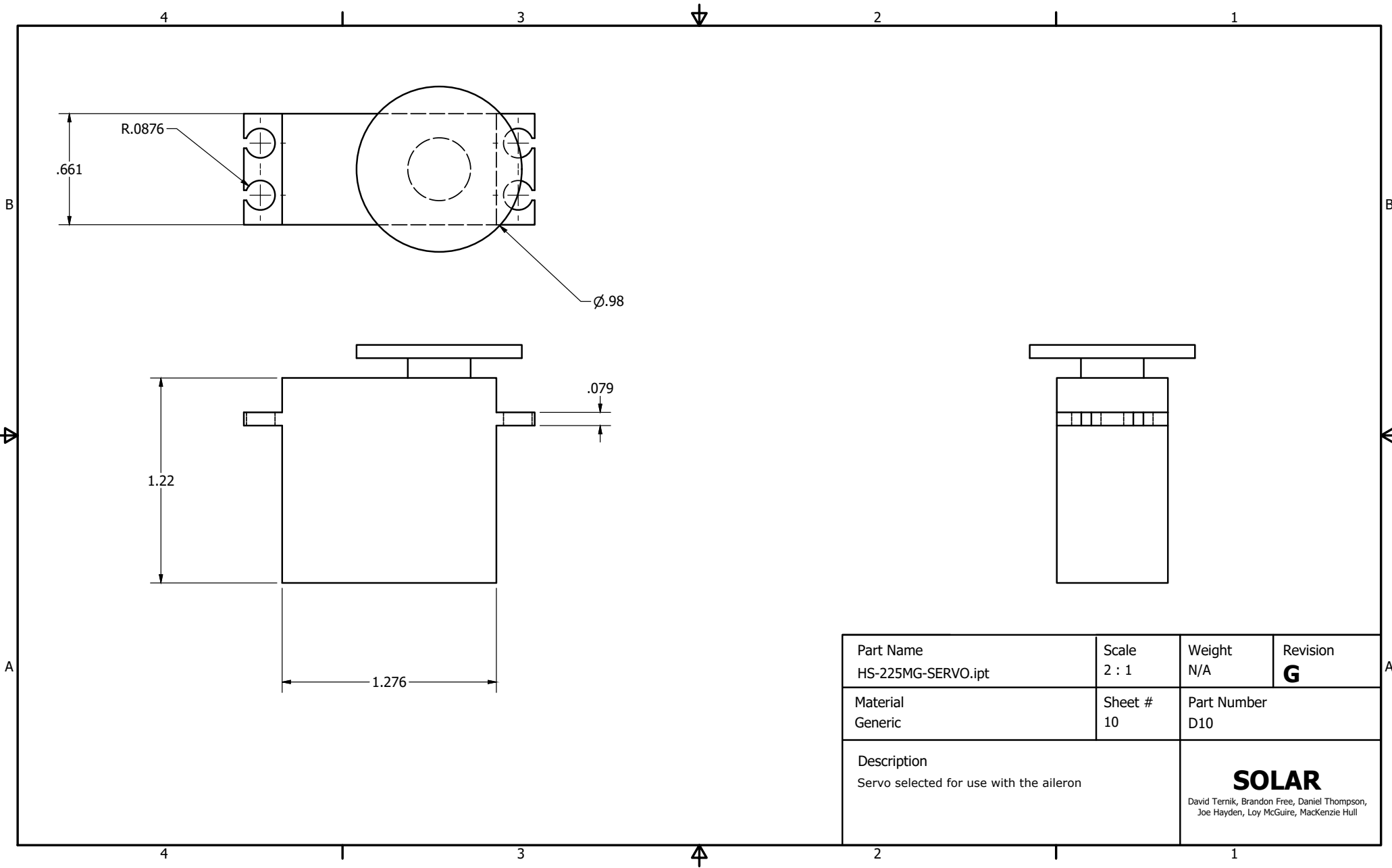

Part Name HS-225MG-SERVO.ipt	Scale 2 : 1	Weight N/A	Revision G
Material Generic	Sheet # 10	Part Number D10	
Description Servo selected for use with the aileron		<p align="center">SOLAR</p> <small>David Ternik, Brandon Free, Daniel Thompson, Joe Hayden, Loy McGuire, MacKenzie Hull</small>	

4

3

2

1

B

B

41.00

Ø.25

A

A

Part Name LEADING-EDGE.ipt	Scale 0.25	Weight 0.009 lbmass	Revision G
Material Balsa	Sheet # 11	Part Number D11	
Description Dowel rod used for leading edge		<p align="center">SOLAR</p> <small>David Ternik, Brandon Free, Daniel Thompson, Joe Hayden, Loy McGuire, MacKenzie Hull</small>	

4

3

2

1

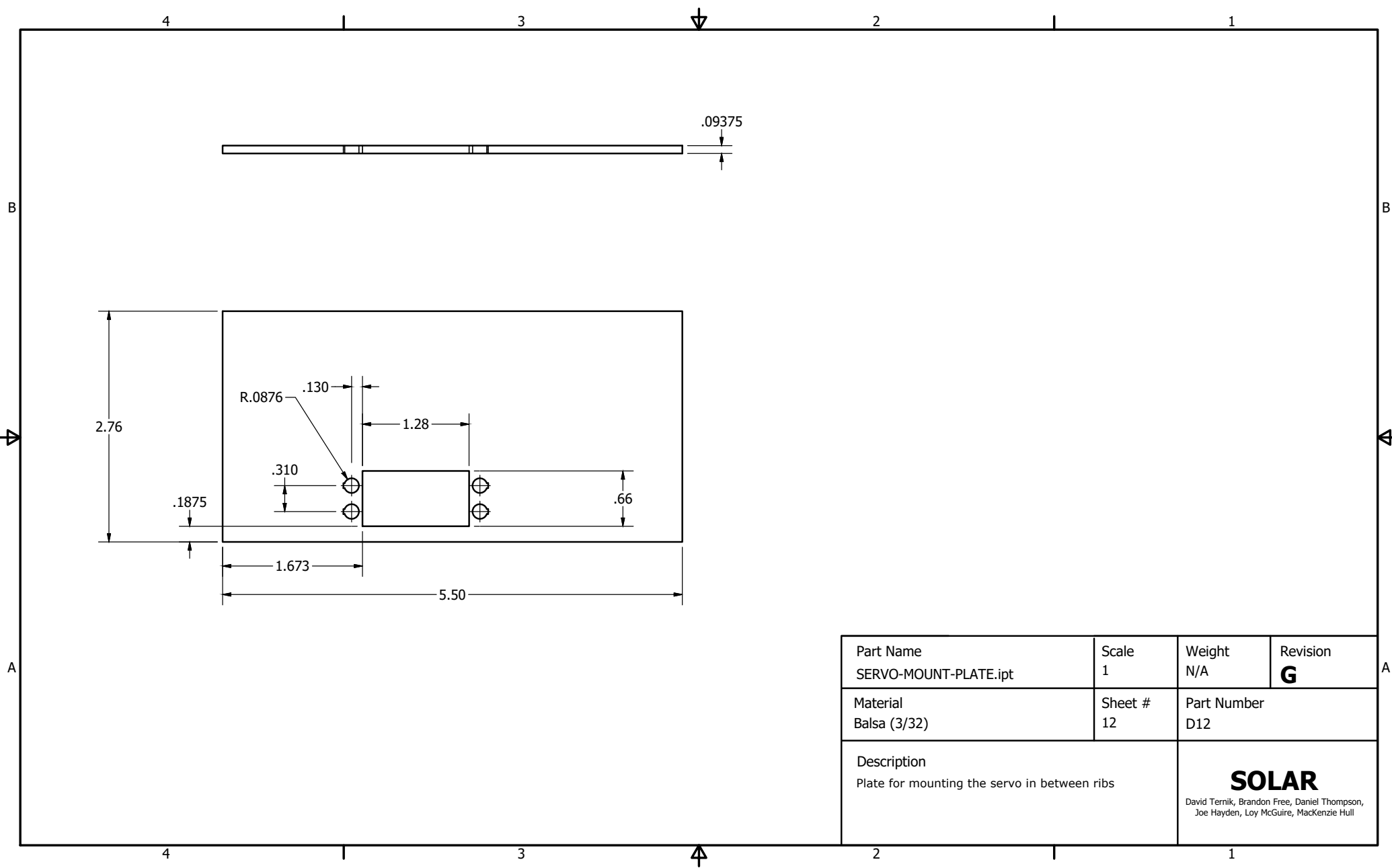

Part Name SERVO-MOUNT-PLATE.ipt	Scale 1	Weight N/A	Revision G
Material Balsa (3/32)	Sheet # 12	Part Number D12	
Description Plate for mounting the servo in between ribs		<p align="center">SOLAR</p> <small>David Ternik, Brandon Free, Daniel Thompson, Joe Hayden, Loy McGuire, MacKenzie Hull</small>	

4

3

2

1

B

B

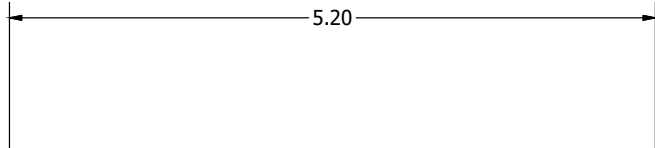
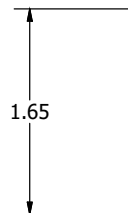
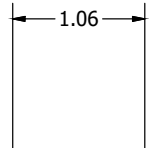

LECTRON PRO 3S 50C (2C)11.1V
5200mAh

A

A

4

3

2

1

A

A

Part Name BATTERY-PACK-LECTRON.ipt	Scale 1 : 1	Weight 0.772 lbmass	Revision G
Material LECTRON Pro 3S	Sheet # 1	Part Number E1	
Description		<p align="center">SOLAR</p> <p align="center">David Ternik, Brandon Free, Daniel Thompson, Joe Hayden, Loy McGuire, MacKenzie Hull</p>	

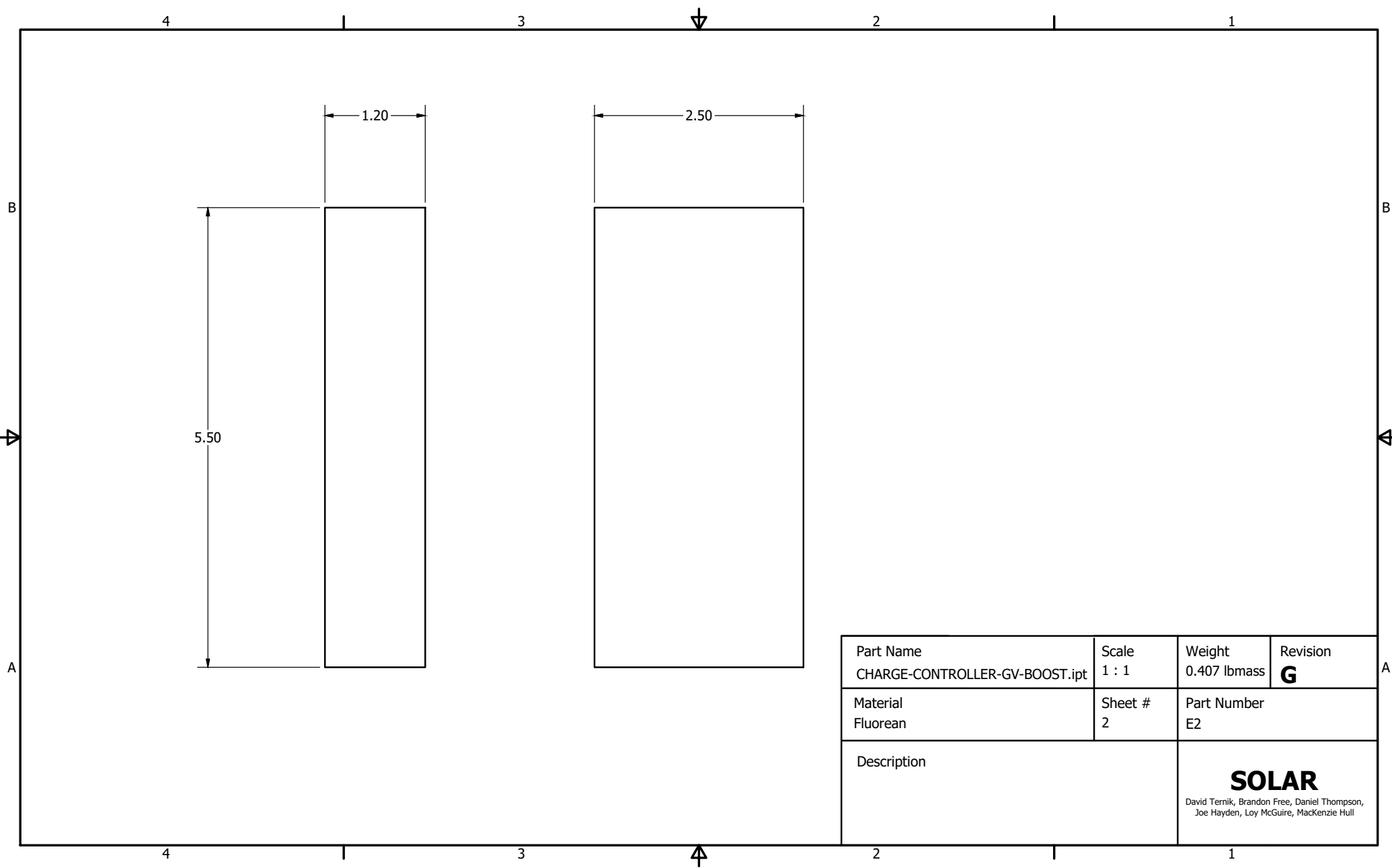

Part Name CHARGE-CONTROLLER-GV-BOOST.ipt	Scale 1 : 1	Weight 0.407 lbmass	Revision G
Material Fluorean	Sheet # 2	Part Number E2	
Description		SOLAR <small>David Ternik, Brandon Free, Daniel Thompson, Joe Hayden, Loy McGuire, MacKenzie Hull</small>	

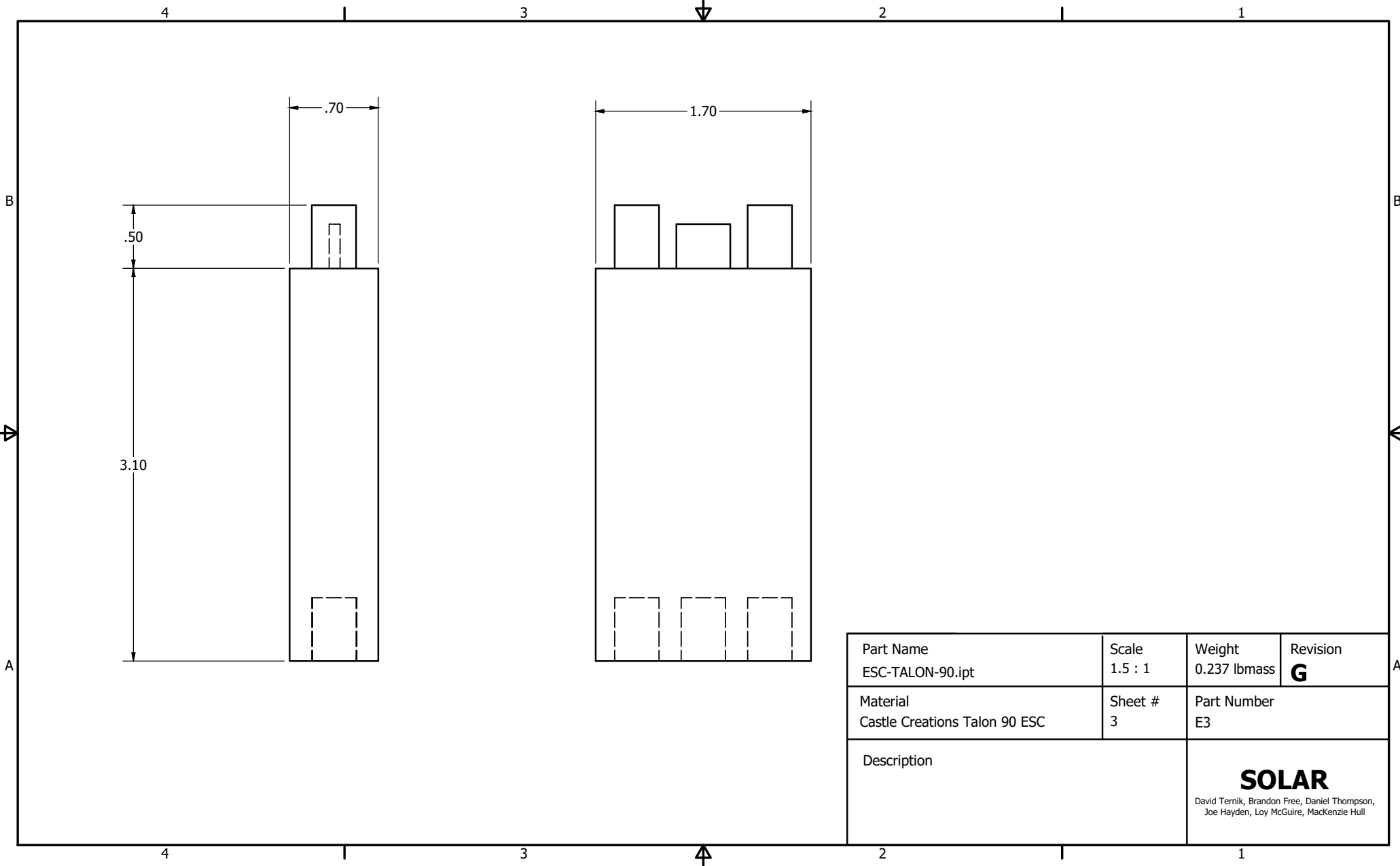

Part Name ESC-TALON-90.ipt	Scale 1.5 : 1	Weight 0.237 lbmass	Revision G
Material Castle Creations Talon 90 ESC	Sheet # 3	Part Number E3	
Description		SOLAR <small>David Ternik, Brandon Free, Daniel Thompson, Joe Hayden, Loy McGuire, MacKenzie Hull</small>	

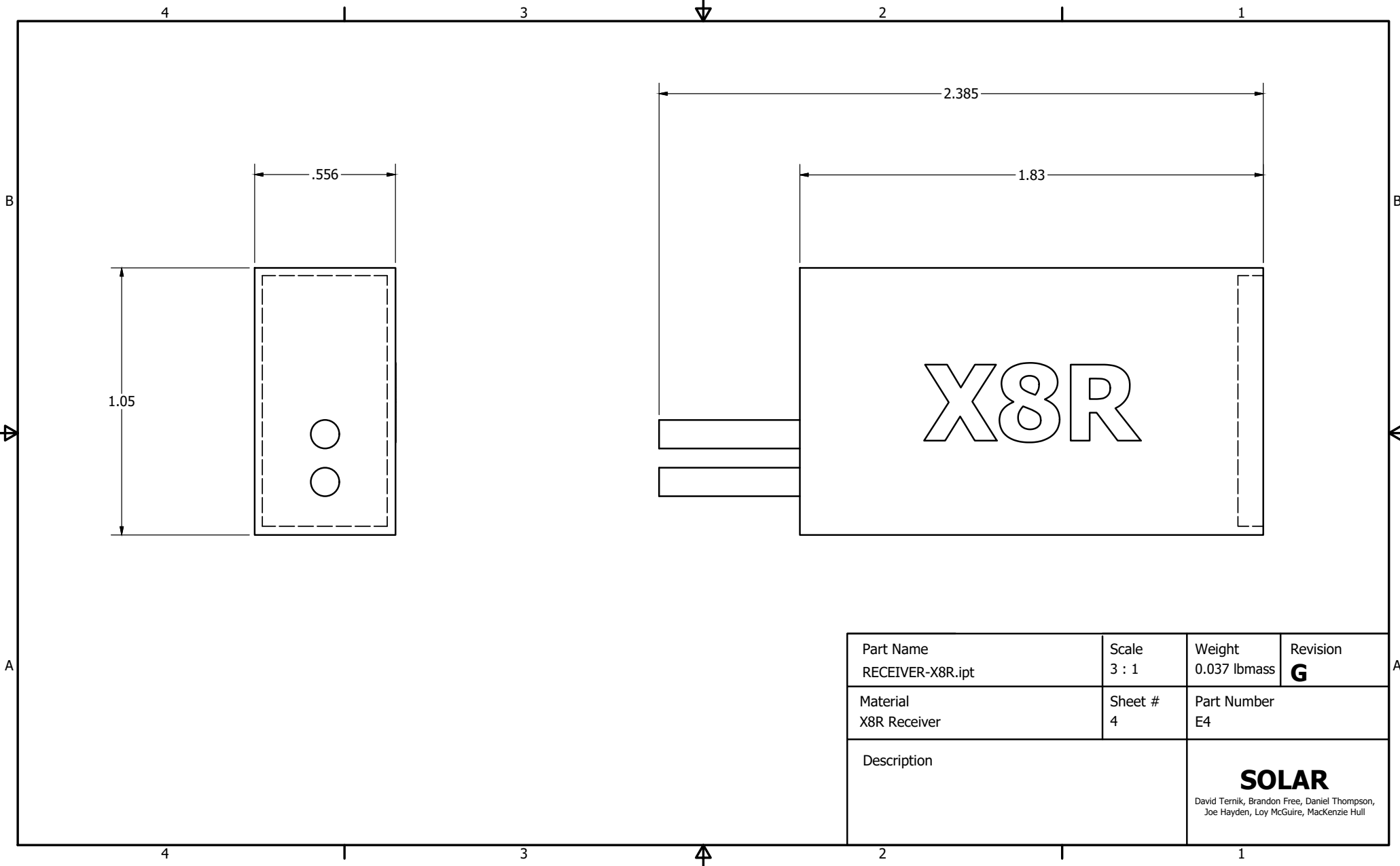

Part Name RECEIVER-X8R.ipt	Scale 3 : 1	Weight 0.037 lbmass	Revision G
Material X8R Receiver	Sheet # 4	Part Number E4	
Description		<p align="center">SOLAR</p> <p align="center">David Ternik, Brandon Free, Daniel Thompson, Joe Hayden, Loy McGuire, MacKenzie Hull</p>	

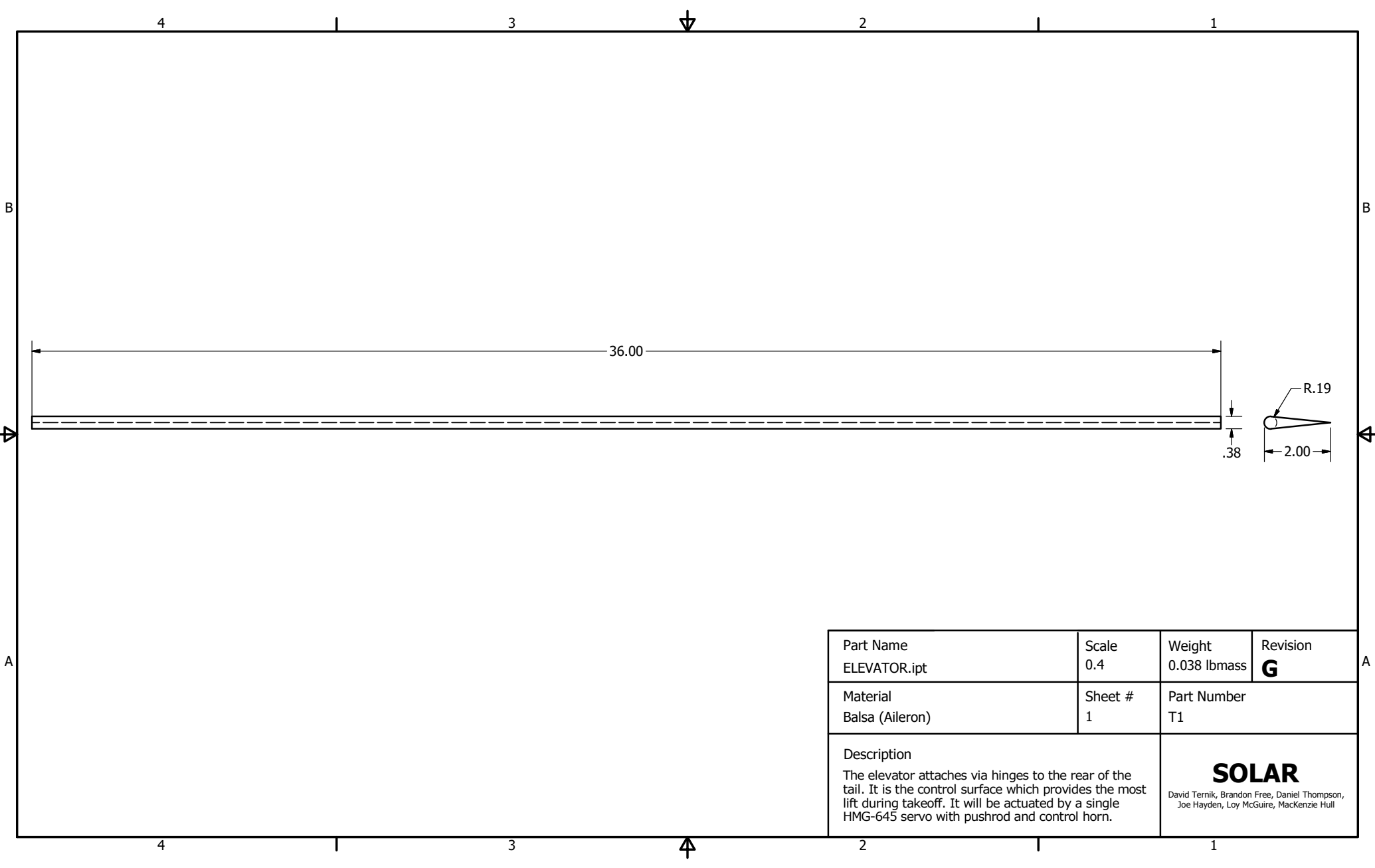

Part Name ELEVATOR.ipt	Scale 0.4	Weight 0.038 lbmass	Revision G
Material Balsa (Aileron)	Sheet # 1	Part Number T1	
Description The elevator attaches via hinges to the rear of the tail. It is the control surface which provides the most lift during takeoff. It will be actuated by a single HMG-645 servo with pushrod and control horn.		SOLAR <small>David Ternik, Brandon Free, Daniel Thompson, Joe Hayden, Loy McGuire, MacKenzie Hull</small>	

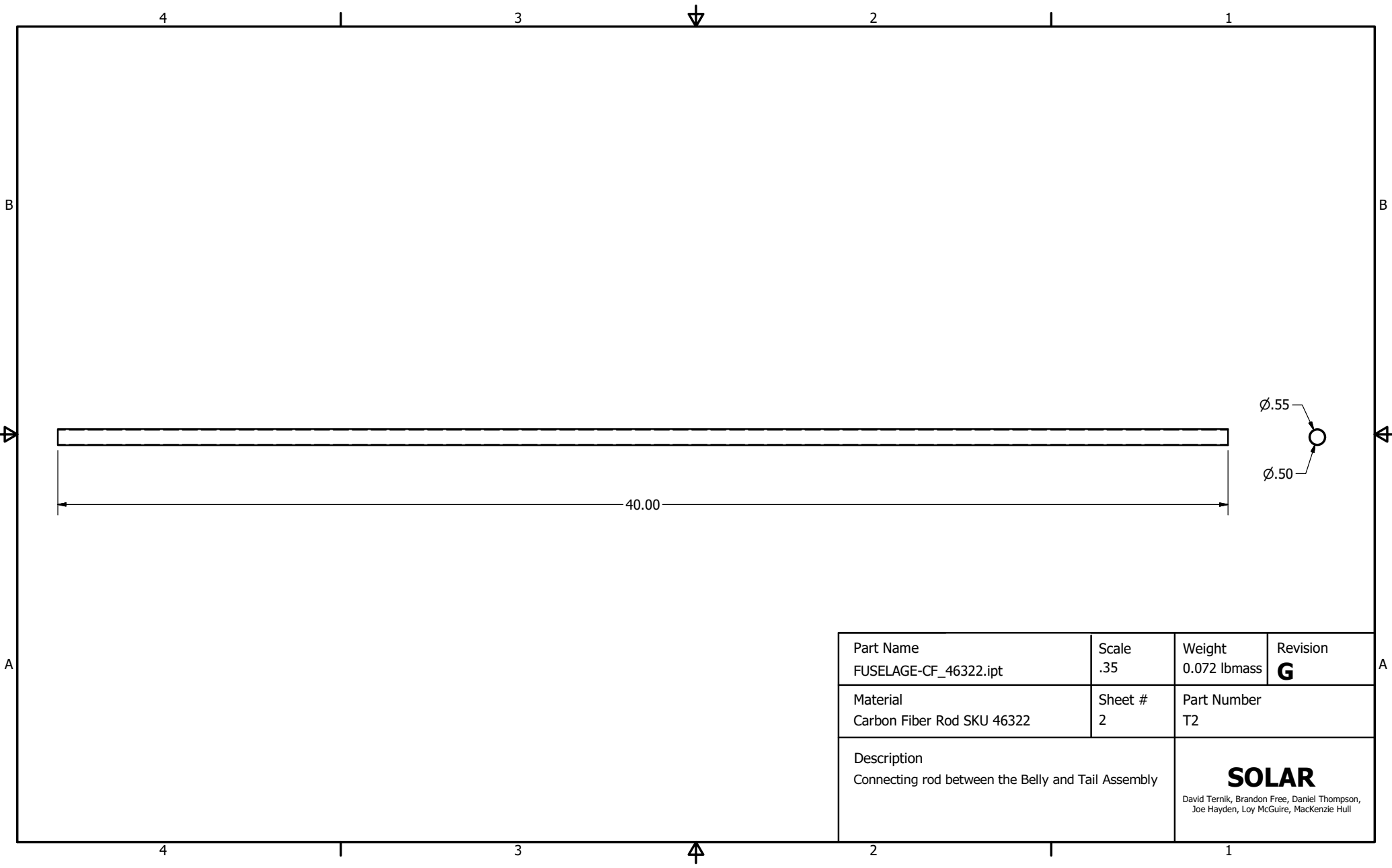

Part Name FUSELAGE-CF_46322.ipt	Scale .35	Weight 0.072 lbmass	Revision G
Material Carbon Fiber Rod SKU 46322	Sheet # 2	Part Number T2	
Description Connecting rod between the Belly and Tail Assembly		<p align="center">SOLAR</p> <small>David Ternik, Brandon Free, Daniel Thompson, Joe Hayden, Loy McGuire, MacKenzie Hull</small>	

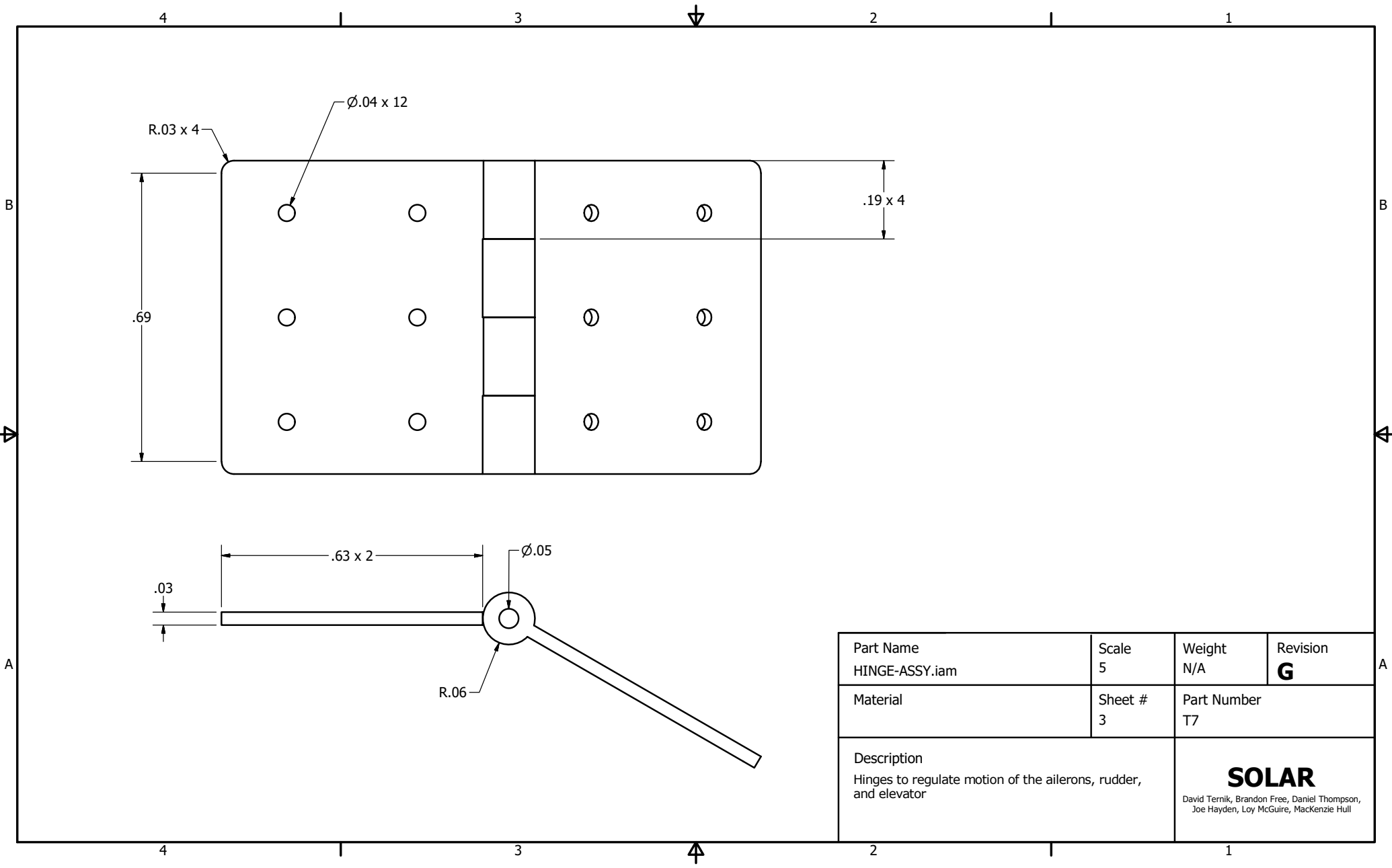

Part Name HINGE-ASSY.iam	Scale 5	Weight N/A	Revision G
Material	Sheet # 3	Part Number T7	
Description Hinges to regulate motion of the ailerons, rudder, and elevator		SOLAR David Ternik, Brandon Free, Daniel Thompson, Joe Hayden, Loy McGuire, MacKenzie Hull	

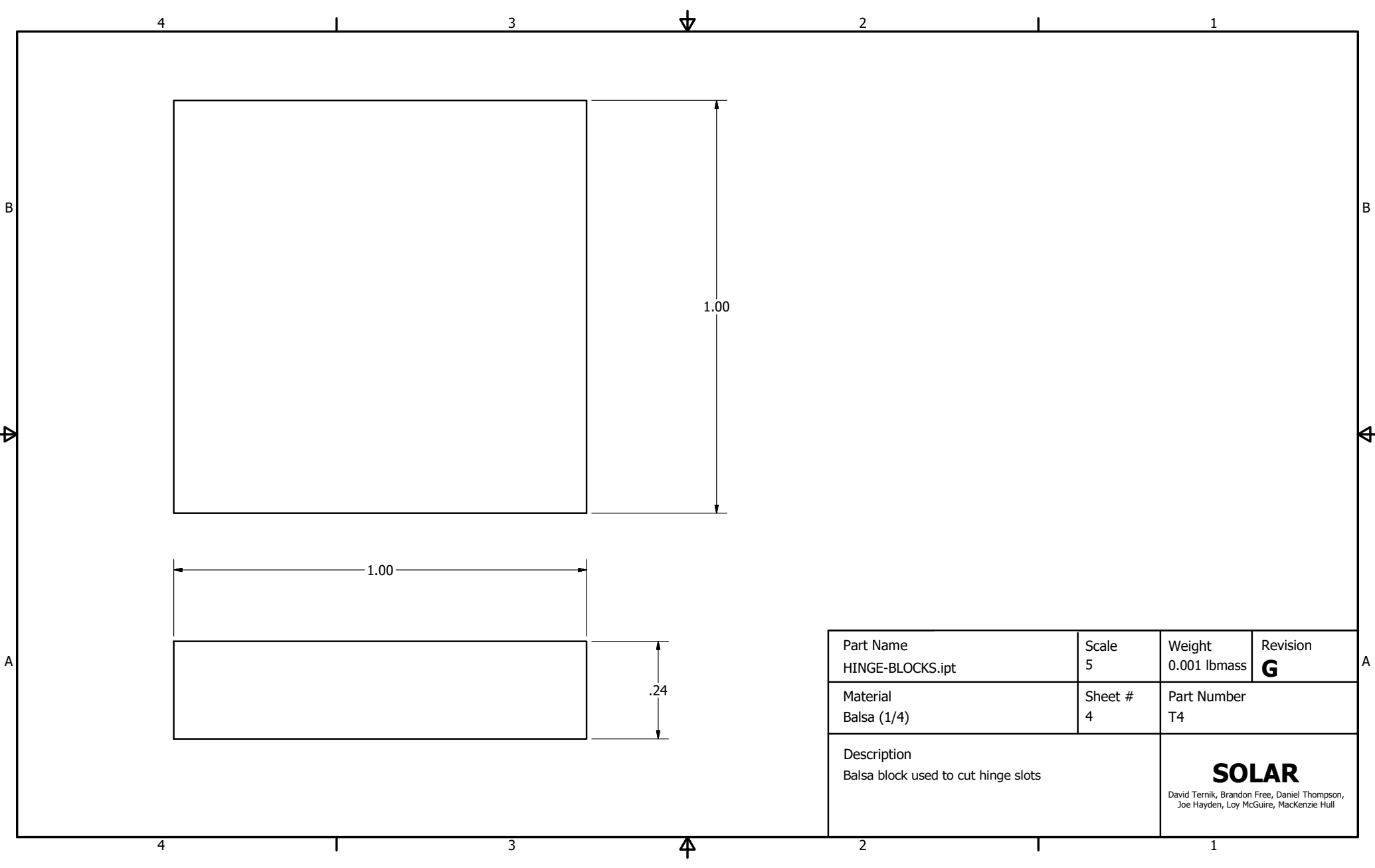

Part Name HINGE-BLOCKS.ipt	Scale 5	Weight 0.001 lbmass	Revision G
Material Balsa (1/4)	Sheet # 4	Part Number T4	
Description Balsa block used to cut hinge slots		SOLAR <small>David Ternik, Brandon Free, Daniel Thompson, Joe Hayden, Loy McGuire, MacKenzie Hull</small>	

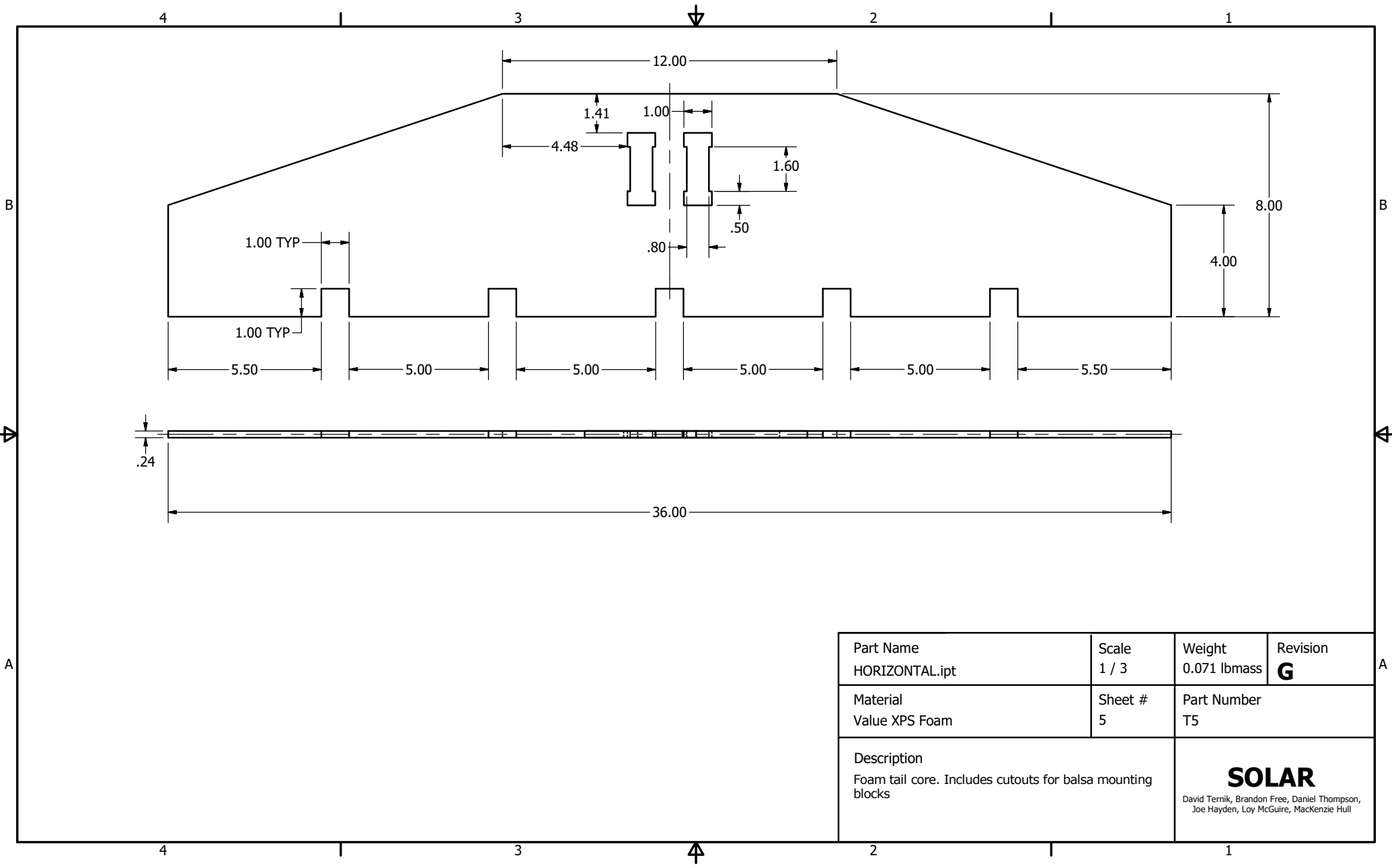

Part Name HORIZONTAL.ipt	Scale 1 / 3	Weight 0.071 lbmass	Revision G
Material Value XPS Foam	Sheet # 5	Part Number T5	
Description Foam tail core. Includes cutouts for balsa mounting blocks		SOLAR <small>David Ternik, Brandon Free, Daniel Thompson, Joe Hayden, Loy McGuire, MacKenzie Hull</small>	

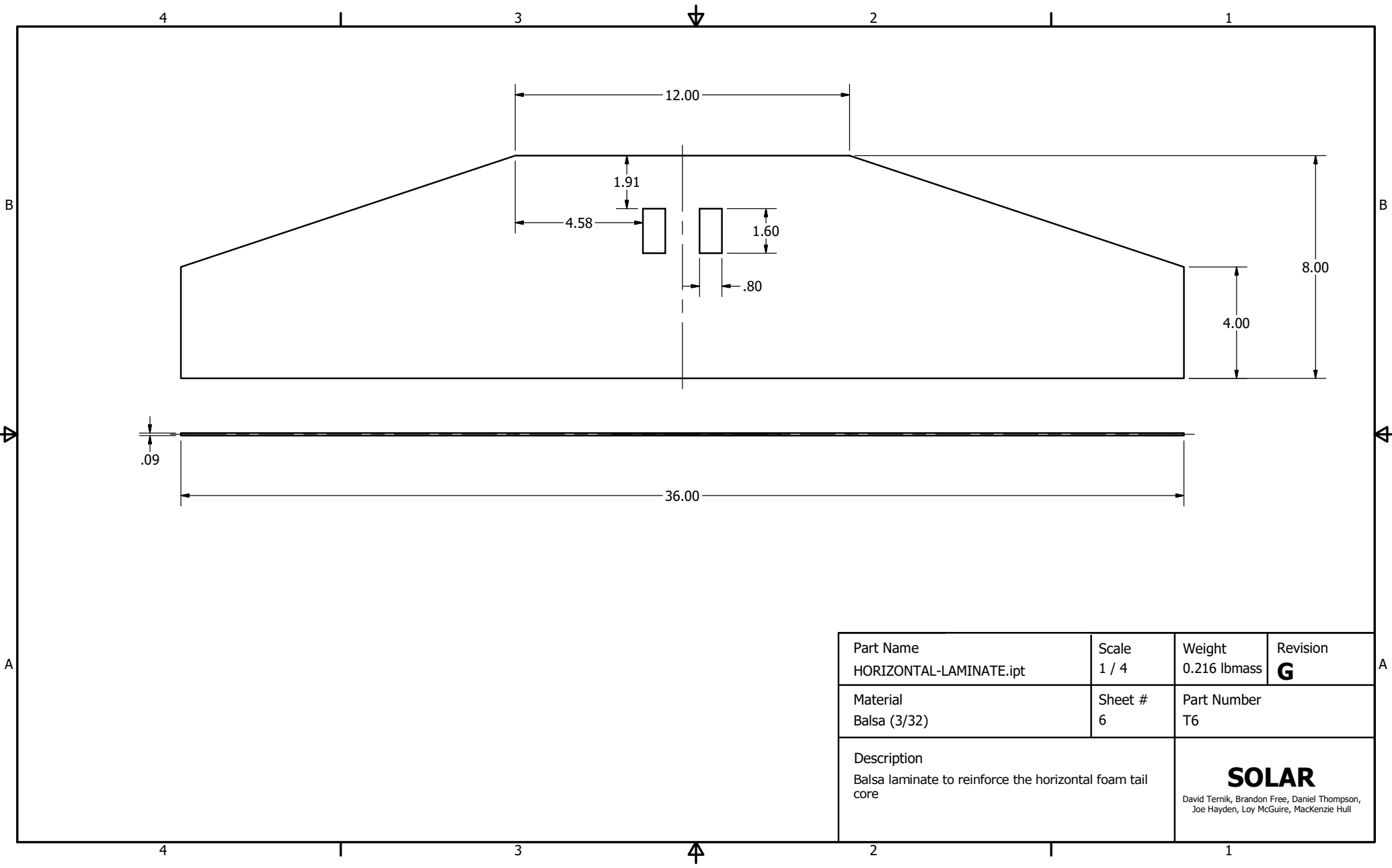

Part Name HORIZONTAL-LAMINATE.ipt	Scale 1 / 4	Weight 0.216 lbmass	Revision G
Material Balsa (3/32)	Sheet # 6	Part Number T6	
Description Balsa laminate to reinforce the horizontal foam tail core		SOLAR <small>David Ternik, Brandon Free, Daniel Thompson, Joe Hayden, Loy McGuire, MacKenzie Hull</small>	

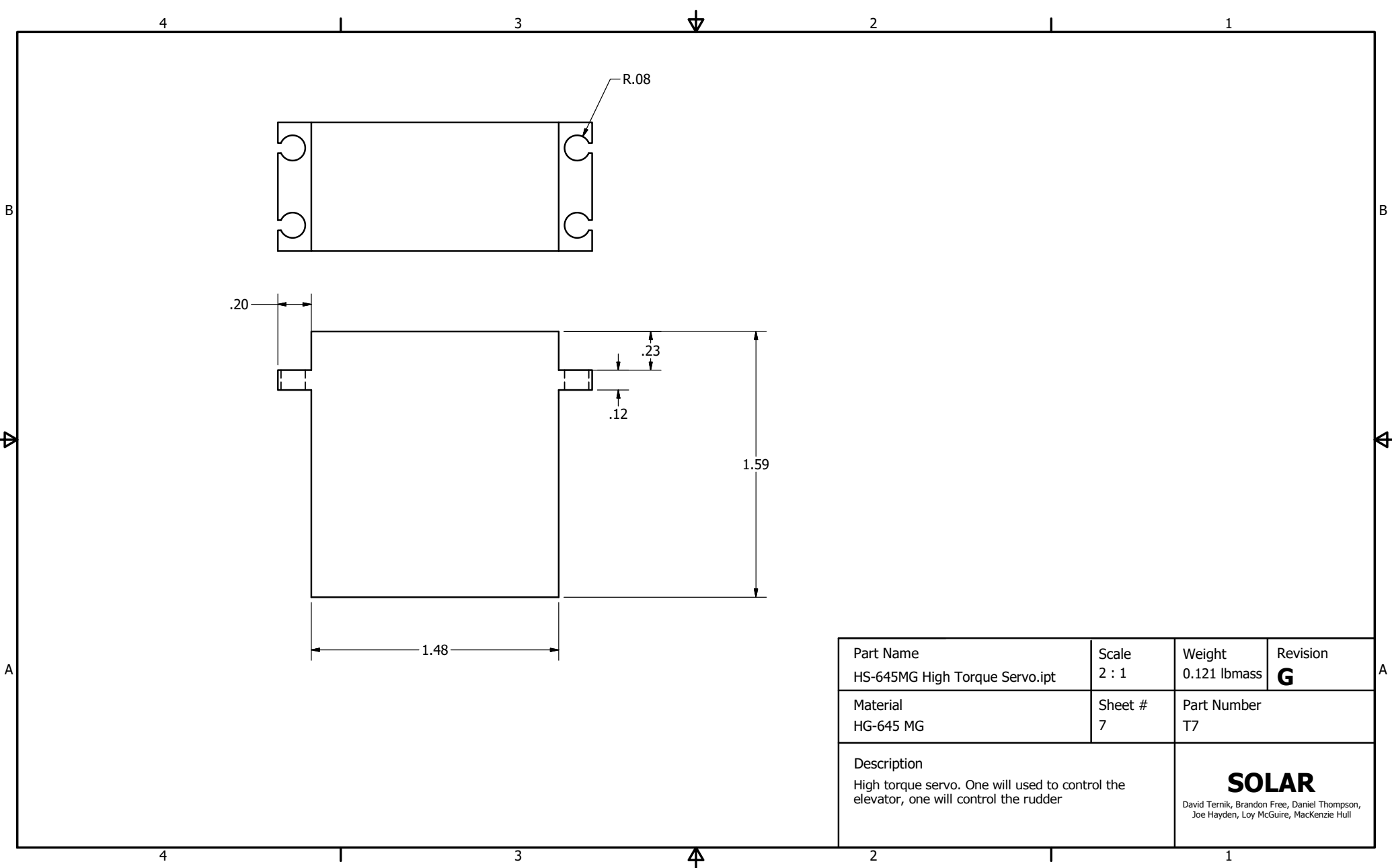

4 3 2 1

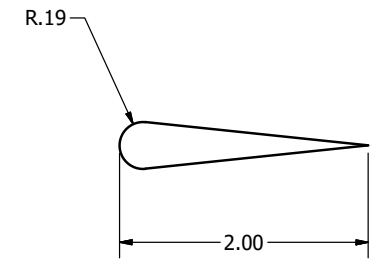
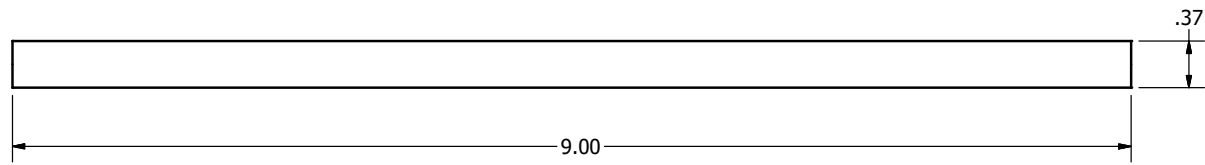

B

B

A

A

Part Name RUDDER.ipt	Scale 1	Weight 0.010 lbmass	Revision G
Material Balsa (Aileron)	Sheet # 8	Part Number T8	
Description Control surface used to yaw		<p align="center">SOLAR</p> <p align="center">David Ternik, Brandon Free, Daniel Thompson, Joe Hayden, Loy McGuire, MacKenzie Hull</p>	

4 3 2 1

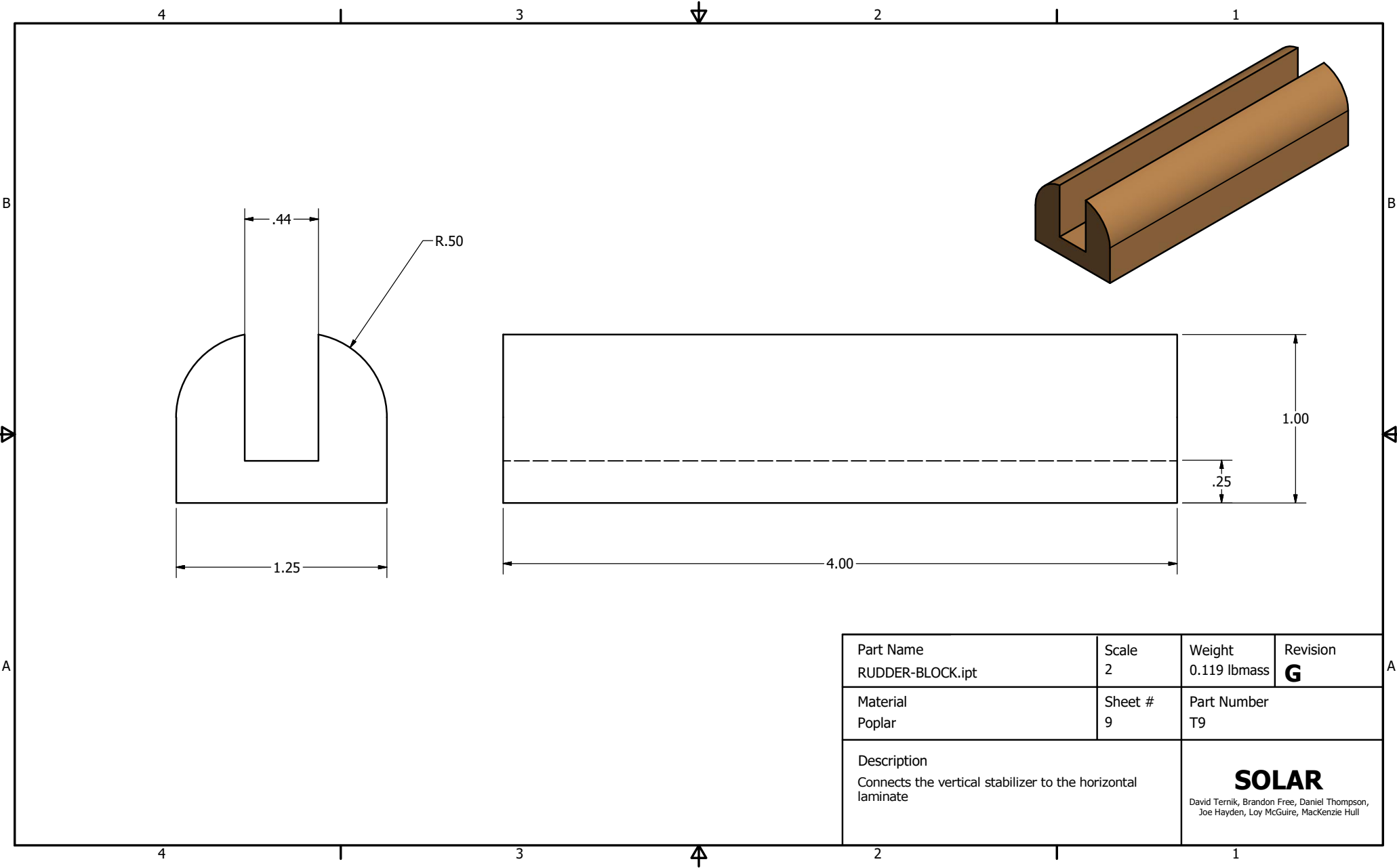

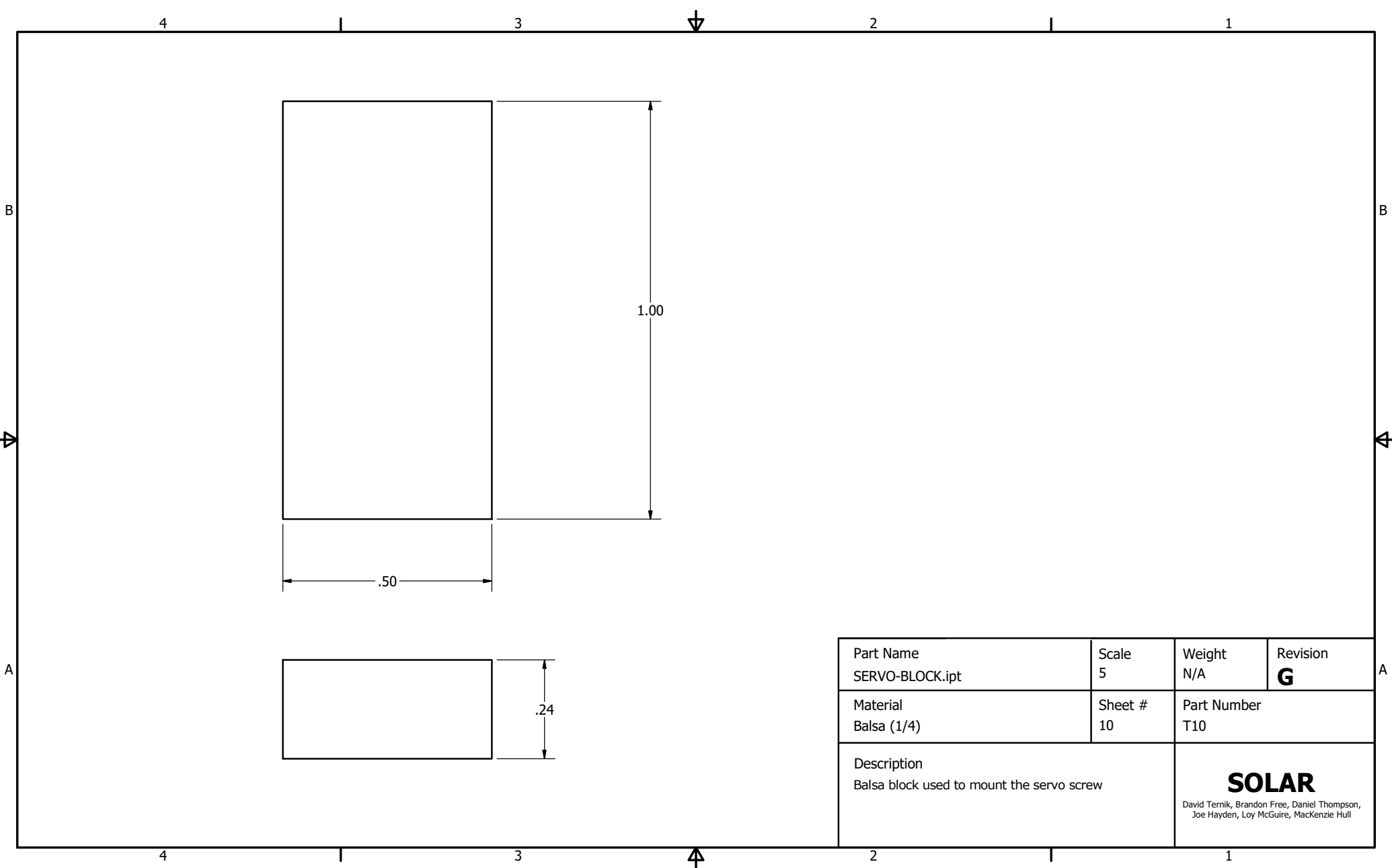

Part Name SERVO-BLOCK.ipt	Scale 5	Weight N/A	Revision G
Material Balsa (1/4)	Sheet # 10	Part Number T10	
Description Balsa block used to mount the servo screw		<p style="text-align: center;">SOLAR</p> <small>David Ternik, Brandon Free, Daniel Thompson, Joe Hayden, Loy McGuire, MacKenzie Hull</small>	

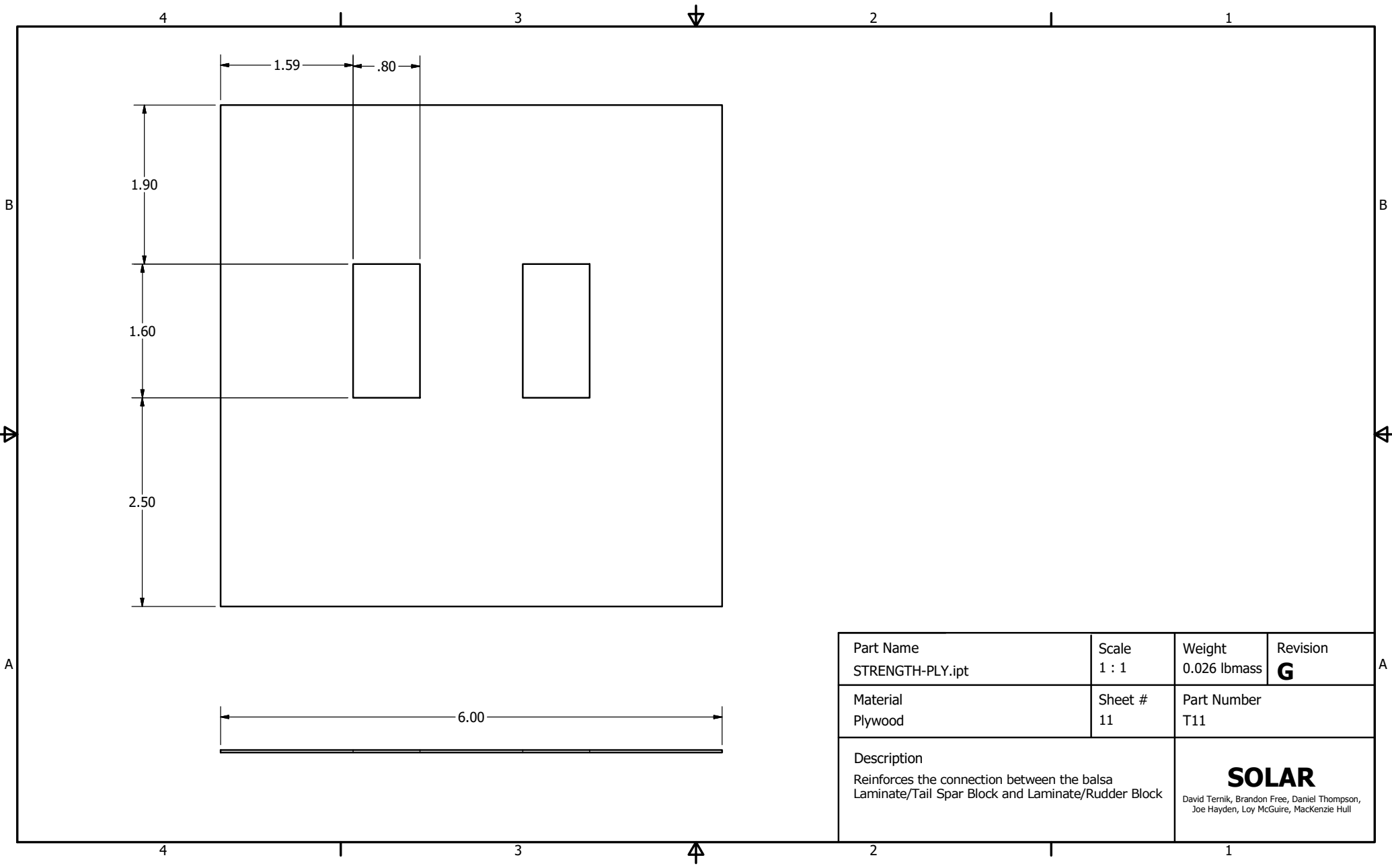

Part Name STRENGTH-PLY.ipt	Scale 1 : 1	Weight 0.026 lbmass	Revision G
Material Plywood	Sheet # 11	Part Number T11	
Description Reinforces the connection between the balsa Laminate/Tail Spar Block and Laminate/Rudder Block		<p align="center">SOLAR</p> <small>David Ternik, Brandon Free, Daniel Thompson, Joe Hayden, Loy McGuire, MacKenzie Hull</small>	

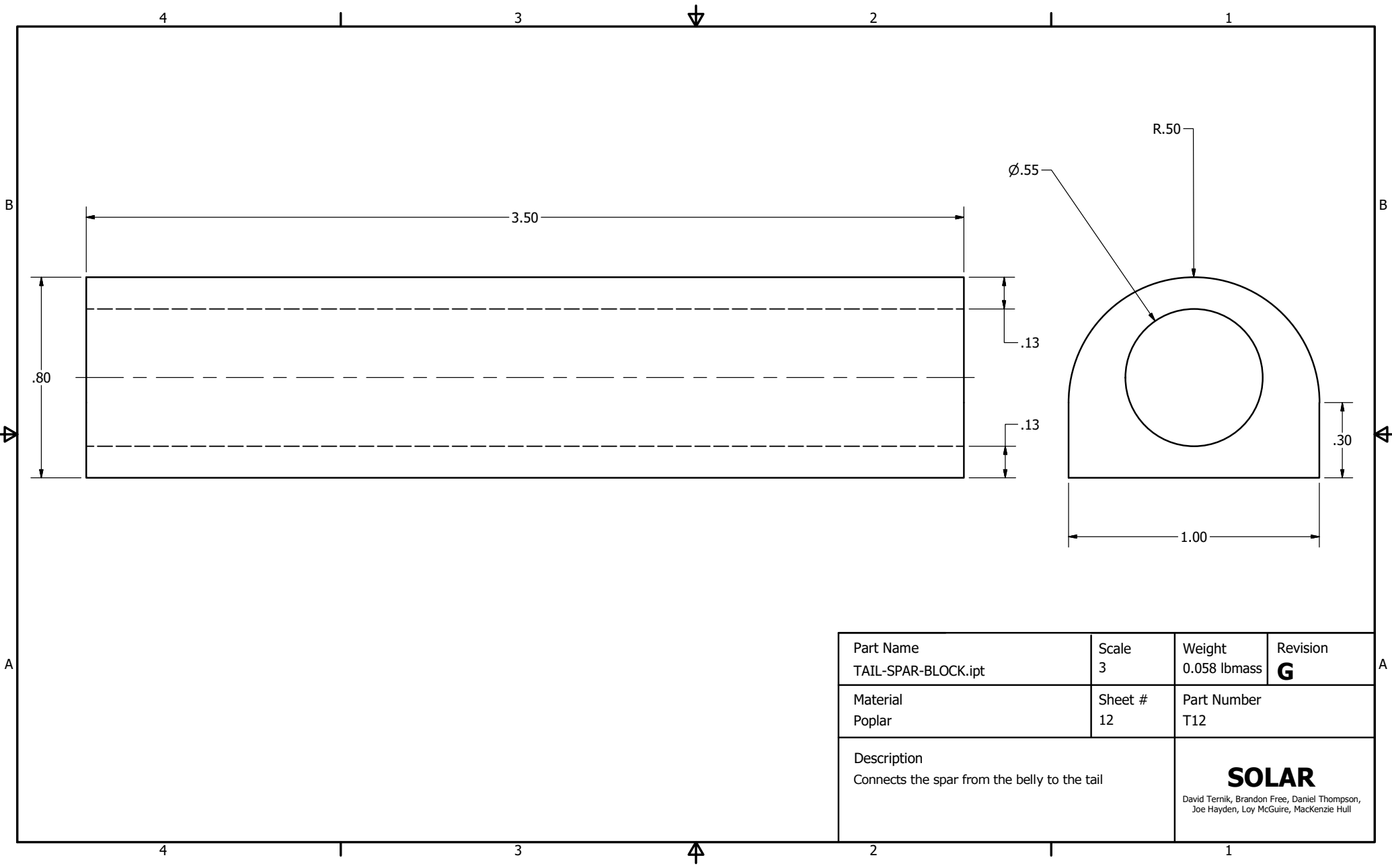

Part Name TAIL-SPAR-BLOCK.ipt	Scale 3	Weight 0.058 lbmass	Revision G
Material Poplar	Sheet # 12	Part Number T12	
Description Connects the spar from the belly to the tail		<p align="center">SOLAR</p> <p align="center">David Ternik, Brandon Free, Daniel Thompson, Joe Hayden, Loy McGuire, MacKenzie Hull</p>	

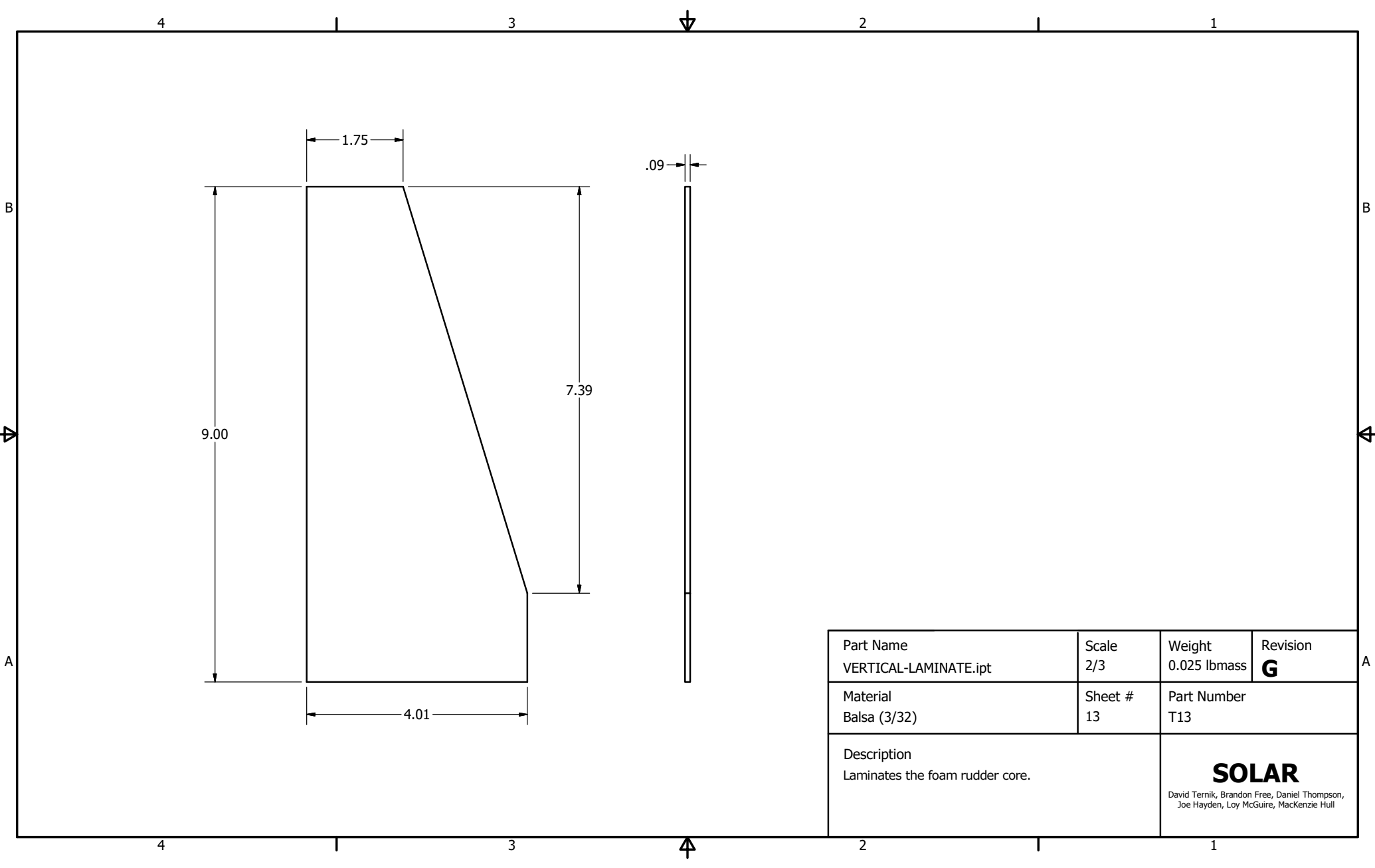

Part Name VERTICAL-LAMINATE.ipt	Scale 2/3	Weight 0.025 lbmass	Revision G
Material Balsa (3/32)	Sheet # 13	Part Number T13	
Description Laminates the foam rudder core.		<p align="center">SOLAR</p> <small>David Ternik, Brandon Free, Daniel Thompson, Joe Hayden, Loy McGuire, MacKenzie Hull</small>	

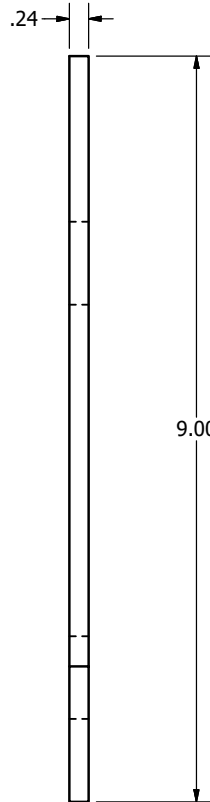
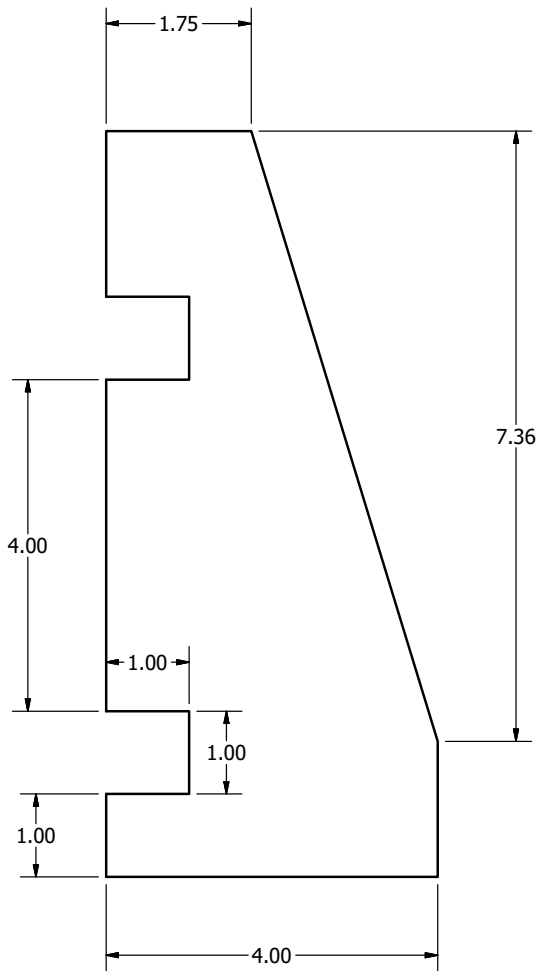

Part Name VERTICAL-STABILIZER.ipt	Scale 2/3	Weight 0.008 lbmass	Revision G
Material Value XPS Foam	Sheet # 14	Part Number T14	
Description Foam core for the tale rudder. Includes 1" cutouts for hinge blocks.		SOLAR David Ternik, Brandon Free, Daniel Thompson, Joe Hayden, Loy McGuire, MacKenzie Hull	

Appendix B Final Schematic

All 50 Panels in Series

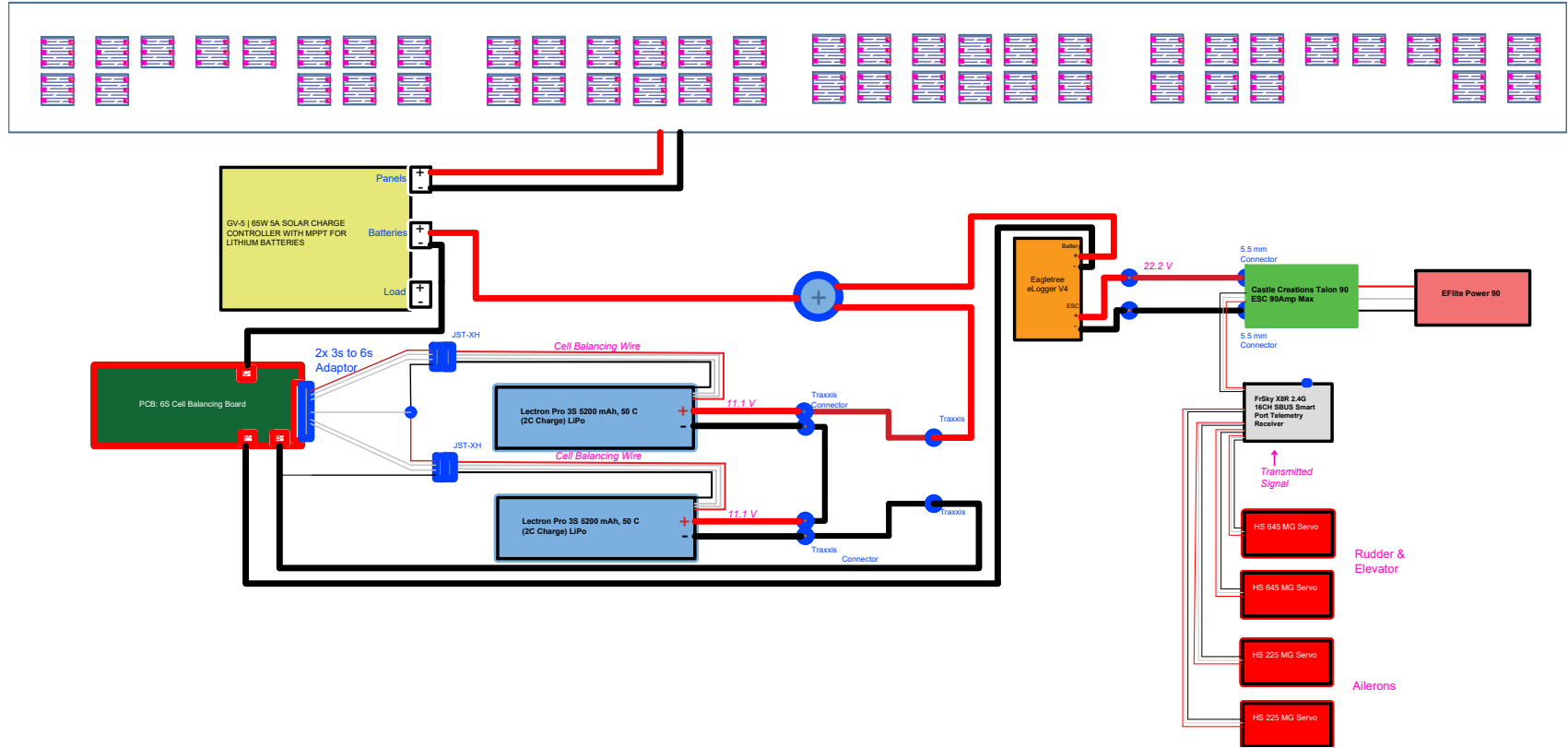

Appendix C Bill of Materials

Component	Part Name	Price	Quantity	Shipping	Total	Supplier	Date
MonoKote	MonoKote	\$13.99	1	\$0.00	\$13.99	Hobby Shop	Oct 26
Balsa sheets for ribs	1/8" x 6" x 36"	\$4.99	2	\$0.00	\$9.98	Hobby Shop	Oct 26
Balsa sheets for ribs	3/16" x 6" x 36"	\$5.15	2	\$0.00	\$10.30	Hobby Shop	Oct 26
Wood Dowels	3/16" x 48"	\$1.19	1	\$0.00	\$1.19	Gillman's	Oct 26
Wood Dowels	5/8" x 48"	\$3.21	1	\$0.00	\$3.21	Gillman's	Oct 26
Wood Dowels	1/8" x 48"	\$0.91	1	\$0.00	\$0.91	Gillman's	Oct 26
C.G. Finder	Aircraft balancer	\$29.99	1	\$0.00	\$29.99	Hobby Shop	Oct 26
Servo	HS-645MG Ultra Torque	\$30.99	1	\$0.00	\$30.99	Hobby Shop	Oct 26
Micro Servo	HS-82MG Micro	\$21.99	1	\$0.00	\$21.99	Hobby Shop	Oct 26
Aluminum Spar	Aluminum Dowel	\$1.50	1	\$0.00	\$1.50	Hobby Shop	Oct 26
Brushless RC Motor	E-Flite Power 90	\$128.69	1	\$0.00	\$128.69	Amazon	Nov 11
Electronic Speed Control & Battery Eliminator Circuit	Castle Creations Talon 90 Amp Electronic Speed Controller with Heavy Duty BEC	\$67.80	1	\$0.00	\$67.80	Amazon	Nov 11
ESC Programming Cable	Castle Creations Castle Link USB Programming Adapter	\$21.21	1	\$0.00	\$21.21	Amazon	Nov 11

Component	Part Name	Price	Quantity	Shipping	Total	Supplier	Date
High Current Connector	Castle Creations 5.5mm Bullet Connectors	\$8.89	1	\$0.00	\$8.89	Amazon	Nov 11
RC Receiver	FrSky X8R 2.4G 16CH SBUS Smart Port Telemetry Receiver	\$37.97	1	\$0.00	\$37.97	Amazon	Nov 11
Camera	GoPro HERO5 Session	\$299.00	1	\$0.00	\$299.00	Amazon	Nov 11
Flexible Solar Cells	SunPower C60 (Q:32)	\$86.49	1	\$0.00	\$86.49	Ebay	Nov 21
Drawer Slides for Motor Thrust Testing	24" Drawer Slides (Q:2)	\$11.00	1	\$0.00	\$11.00	ACE	Nov 21
Wooden Propeller	XOAR PJM-E 18x8 RC Model Electric Airplane Propeller	\$20	1	\$0.00	\$20.00	Amazon	Nov 21
Wooden Propeller	XOAR PJN 16x8 RC Model Electric Airplane Propeller	\$15	1	\$0.00	\$15.00	Amazon	Nov 21
HobbyKing Folding Carbon Fiber Propeller (1pc)	Folding Carbon Fiber Propeller	\$26.89	1	\$6.00	\$32.89	Amazon	Nov 21
HobbyKing Folding Propeller W/Alloy Hub 40mm/4.0mm 12x8.5 (1pc)	Propeller Hub	\$15.89	1	\$8.49	\$24.38	Amazon	Nov 21
SD card	SanDisk Extreme PLUS 64GB	\$24.99	1	\$0.00	\$24.99	Amazon	Nov 28
Carbon fiber (72" Spar)	SKU: 46322	\$60.00	4	\$0.00	\$240.00	Rockwest Composites	Feb 3
Flight surfaces: Fli-Power Value XPS RC Model Foam, 6mm, 16 Sheets	RCF001348	\$49.99	1	\$0.00	\$49.99	RC Foam	Feb 3

Component	Part Name	Price	Quantity	Shipping	Total	Supplier	Date
Carbon fiber fabric	SKU: 13005-D	\$55.99	1	\$0.00	\$55.99	Rockwest Composites	Feb 3
Electrical Compartment Mold	sheet metal from shop	\$0.00	1	\$0.00	\$0.00	Shop	Feb 3
Center connector	McMaster 9578T26	\$32.48	1	\$0.00	\$32.48	McMaster	Feb 3
Dihedral connector	McMaster 9056K66	\$4.70	1	\$0.00	\$4.70	McMaster	Feb 3
Horizontal stabilizer connector	McMaster 8981T63	\$2.16	2	\$0.00	\$4.32	McMaster	Feb 3
Vertical stabilizer connector	McMaster 3177T12	\$5.97	2	\$0.00	\$11.94	McMaster	Feb 3
Flexible Solar Cells	SunPower C60 (Q:38)	\$106.49	1	\$0.00	\$106.49	Ebay	Feb 3
Monokote	SKY BULE	\$13.99	1	\$0.00	\$13.99	Hobby Shop	Feb 2
Aileron Balsa	Balsa 3/8x2x36	\$3.10	2	\$0.00	\$6.20	Hobby Shop	Feb 2
Balsa for aileron to rib attachment	1/8x1/2x36 Balsa	\$0.99	2	\$0.00	\$1.98	Hobby Shop	Feb 2
Balsa for ribs	3/16x6x36 Balsa	\$5.15	2	\$0.00	\$10.30	Hobby Shop	Feb 2
Flight surface hinges	HINGES SMALL	\$4.49	1	\$0.00	\$4.49	Hobby Shop	Feb 2
Flight surface control horn	CONTROL HORNS	\$1.29	1	\$0.00	\$1.29	Hobby Shop	Feb 2
Attachment for pushrod to control horn	528 4-40 Gold-N-C1	\$9.99	1	\$0.00	\$9.99	Hobby Shop	Feb 2
Epoxy for hinge attachment	MID-CURE 15 Min	\$9.99	1	\$0.00	\$9.99	Hobby Shop	Feb 2

Component	Part Name	Price	Quantity	Shipping	Total	Supplier	Date
	308 SPHP 15 ST	\$6.99	1	\$0.00	\$6.99	Hobby Shop	Feb 2
Flight surface control horn	CONTROL HORN	\$1.10	2	\$0.00	\$2.20	Hobby Shop	Feb 2
Flight surface control horn	Control Horn Nylon	\$1.10	1	\$0.00	\$1.10	Hobby Shop	Feb 2
Flight surface control horn	CONTROL HORN	\$1.10	1	\$0.00	\$1.10	Hobby Shop	Feb 2
Epoxy mixing cup	EPOXY MIXING CUP	\$0.10	1	\$0.00	\$0.10	Hobby Shop	Feb 2
Epoxy brushes	EPOXY BRUSH	\$0.20	2	\$0.00	\$0.40	Hobby Shop	Feb 2
Pushrods for ailerons	Threaded pushrods	\$0.65	2	\$0.00	\$1.30	Hobby Shop	Feb 2
Pushrods for tail flight surfaces	THRD ROD 4-40	\$1.79	3	\$0.00	\$5.37	Hobby Shop	Feb 2
Batteries	Lectron Pro, 3S 5200 mAh	\$43.99	3	\$5.95	\$137.92	Ebay	Feb 14
Traxxas Series Harness		\$8.00	1	\$0.00	\$8.00	Hobby Shop	Feb 21
Wire	AWG 12, 25 ft length	\$29.99	1	\$0.00	\$29.99	Hobby Shop	Feb 21
Charge Controller	Genasun GVB-Li-8	\$320.00	1	\$7.99	\$327.99	Genasun	Feb 14
Bullet Connectors	5.5mm x 3 Bullet Connectors	\$5.49	1	\$0.00	\$5.49	Hobby Shop	Feb 21
pv	Male/Female	\$4.25	1	\$0.00	\$4.25	Hobby Shop	Feb 21
Bullet Connectors	4mm x 3 Bullet Connectors	\$4.99	1	\$0.00	\$4.99	Hobby Shop	Feb 21

Component	Part Name	Price	Quantity	Shipping	Total	Supplier	Date
Servo	HS-645MG Ultra Torque	\$30.99	1	\$0.00	\$30.99	Hobby Shop	Feb 21
Micro Servo	HS-82MG Micro	\$21.99	1	\$0.00	\$21.99	Hobby Shop	Feb 21
Balsa Rods		\$17.41	1	\$0.00	\$17.41	Gilman's	Feb 28
Servo Wires	1ft Servo wire extensions (pack of 10)	\$5.80	1	\$0.00	\$5.80	Amazon	Mar 6
Velcro	1" x 15'	\$7.89	1	\$0.00	\$7.89	Amazon	Mar 6
Wood Glue	Tite Bond	\$4.25	1	\$0.00	\$4.25	Hobby Shop	Mar 7
Balsa	Balsa for ribs and potential solar panel frame	\$32.92	1	\$0.00	\$32.92	Hobby Shop	Mar 7
Clear Monokote		\$14.99	1	\$0.00	\$14.99	Hobby Shop	Mar 7
Balancing with Christy's Charge report (Shipping & Cost variations)	\$62.61	Christy	Mar 10				
Aileron Servos	HS-225MG	\$27.99	2	\$0.00	\$55.98	Hobby Shop	Mar 10
Hinges	Du-bro Heavy Duty	\$6.89	1	\$0.00	\$6.89	Hobby Shop	Mar 10
Plywood (Elevator/Rudder)	1/32 x 6 x 12	\$2.65	2	\$0.00	\$5.30	Hobby Shop	Mar 10
Long Balsa Strips (Trailing Edge)	1/8 x 1/2 x 36	\$0.99	5	\$0.00	\$4.95	Hobby Shop	Mar 10
Laminating Balsa	1/32 x 2 x 36	\$0.99	3	\$0.00	\$2.97	Hobby Shop	Mar 10

Component	Part Name	Price	Quantity	Shipping	Total	Supplier	Date
Laminating Balsa	1/32 x 3 x 36	\$1.35	2	\$0.00	\$2.70	Hobby Shop	Mar 10
Laminating Balsa	1/32 x 4 x 36	\$2.69	5	\$0.00	\$13.45	Hobby Shop	Mar 10
Balsa aileron	3/8 x 2 x 36	\$3.10	1	\$0.00	\$3.10	Hobby Shop	Mar 10
Balsa block (hinge slots)	1/2 x 3 x 36	\$4.40	1	\$0.00	\$4.40	Hobby Shop	Mar 10
Threaded Pushrods	12" length	\$0.65	2	\$0.00	\$1.30	Hobby Shop	Mar 10
Foam Spray Adhesive	3M77	\$9.98	1	\$0.00	\$9.98	Lowe's	Mar 10
Sanding block	2 ct 220 grit	\$4.97	1	\$0.00	\$4.97	Lowe's	Mar 10
Cable Ties	11 in (20 count)	\$2.98	1	\$0.00	\$2.98	Lowe's	Mar 10
Poplar Block (elevator/rudder)		\$3.38	2	\$0.00	\$6.76	Lowe's	Mar 10
Wire Nuts	5 count	\$2.96	1	\$0.00	\$2.96	Lowe's	Mar 10
Solar Panel Adhesive	GE Silicone #2, 2.8 oz squeeze	\$3.98	1	\$0.00	\$3.98	Lowe's	Mar 10
Solar Panel Frame	48" x 12" x 1/64" sheets	\$18.65	4	\$15.95	\$90.55	National Balsa	Mar 14
Balsa	48" x 3" x 3/16" sheets	\$5.89	4	\$0.00	\$23.56	National Balsa	Mar 14
PCB	[PCB] for 22.2V (6S) Li-ion Battery Pack (Working 6A, Cutoff 10A)	\$26.99	1	\$13.23	\$40.22	All Battery.com	Mar 15
RETURN SERVOS	Returned HS-82 MG	-\$21.16	2	\$0.00	-\$42.31	Hamilton Hobbies	Mar 10

Component	Part Name	Price	Quantity	Shipping	Total	Supplier	Date
2 3S to 6S Adapter	JST-XH 6S to 2 3S Balance Wire Splitter Adapter	\$5.99	1	\$0.00	\$5.99	Ebay	Mar 15
Aluminum tubing, joint/bumper mount	5/8" OD .495" ID 6" Length 6061 Al Tube	\$5.21	1	\$0.00	\$5.21	McMaster	Mar 28
Solar Cells	Sun Power 21.8% 10 cells	\$36.00	1	\$0.00	\$36.00	Ebay	Mar 30
Motor Mount	Hangar 9 EP Motor Mount w/hdwe	\$22.92	1	\$0.00	\$22.92	Amazon	Mar 30
Tube backing for compression	6061 Aluminum Round Tube	\$8.10	1		\$8.10	McMaster	Mar 30
Shoulder Screws	3/16" OD 3/4" Lg Al Shoulder Screws	\$5.51	2	\$0.00	\$11.02	McMaster	Apr 4
Hex Nuts	8-32 Hex Al Nuts	\$3.96	2	\$0.00	\$7.92	McMaster	Apr 4
Data Logger	eLogger v4	\$69.99	1		\$69.99	Eagle Tree Systems	Apr 4
Center Connector	McMaster: 9578T26	\$32.48	1		\$32.48	McMaster	Apr 4
Extra Carbon Tube	SKU: 46322	\$59.99	2		\$119.98	RockWest Composites	Apr 4
Monokote and Servo Wires		\$29.28	1	\$0.00	\$29.28	Hobby Shop	Apr 10
PCM	22.2 V, 30 A limit	\$58.50	1	\$30.00	\$88.50	Battery Space	Apr 11
Electrical Tape		\$4.59	1	\$0.00	\$4.59	Ace	Apr 13
Tube Heat Shrink		\$2.79	1	\$0.00	\$2.79	Ace	Apr 13
Hex Key Set		\$2.99	1	\$0.00	\$2.99	Ace	Apr 13
Weatherseal Foam	Wing mounting foam	\$19.99	1	\$0.00	\$19.99	Ace	Apr 13
Wood Filler		\$3.99	1	\$0.00	\$3.99	Ace	Apr 13

Component	Part Name	Price	Quantity	Shipping	Total	Supplier	Date
	3S battery charging connector	\$4.99	1	\$0.00	\$4.99	Hamilton Hobbies	Apr 13
	5.5mm Bullet Connectors	\$5.49	1	\$0.00	\$5.49	Hamilton Hobbies	Apr 13
	Clear Monokote	\$15.99	2	\$0.00	\$31.98	Hamilton Hobbies	Apr 13
Final Total					\$2961.43		

Appendix D Manufacturing

A Wings

1 Supplies

- 3/16" Thick Balsa Sheet (Hamilton Hobbies)
- 0.25" OD Softwood Rod (Hamilton Hobbies)
- 1/4 x 1/2 Balsa Strip (Hamilton Hobbies)
- Scrap Balsa (Hamilton Hobbies)
- 0.5" ID Carbon Fiber Tube (Rock West)
- 0.5" ID Aluminum Tube (McMaster)
- 0.5" OD Aluminum Tube (McMaster)
- Scrap Aluminum (shop)
- Hinges (Hamilton Hobby Shop)
- Control Horns (Hamilton Hobby Shop)
- Control Rods (Hamilton Hobby Shop)
- Epoxy (Hamilton Hobby Shop)
- Monokote (Hamilton Hobby Shop)

2 In House Procedures

Process 1: Use laser cutter to make ribs

1. Align 3/16" balsa sheet on laser cutter surface
2. Upload the rib dxf (make sure that dimensions of Illustrator canvas match dimensions of balsa sheet)
3. Run the machine
4. Insert sheet so next set of ribs can be cut but doesn't waste space
5. Repeat steps 1-4 until all ribs are produced

Process 2: Use laser cutter to make jig

1. Align foam sheet on laser cutter surface
2. Upload the appropriate jig dxf (with dihedral or center)
3. Run the machine
4. Insert next sheet so the other jig can be cut

Process 3: Cut carbon spars to length

1. Measure and mark out length on the carbon fiber tube (masking tape can be helpful to mark surface)
2. Using a handsaw, rotate the tube so the teeth cut an initial shallow pass
3. Turn rod on handsaw until cut all the way through
4. Use a wet cloth to clean carbon fiber debris
5. Repeat steps 2-4 until all spars are produced

Process 4: Adhere ribs to spars

1. Place ribs in jig
2. Insert spar into jig leaving a 1/4 inch left
3. Apply epoxy to the spar immediately to the side of the ribs
4. Insert spar the rest of the way
5. Use the leading edge to ensure proper alignment of ribs before the epoxy sets

Process 5: Construct the wing frames

1. Once epoxy on ribs/spar is dry, cut the softwood rod (leading edge) and balsa strip (trailing edge) to size
2. Ensure that the break in the leading edge is attached to a different rib than the break in the trailing edge
3. Do all wood gluing on wax paper
4. Use wood glue to connect the break in the leading and trailing edges with a butt joint
5. Use wood glue to attach leading and trailing edges to each rib
6. Wrap leading edge and spar with masking tape to apply pressure
7. Place wax paper and soft-cover books on entire frame to apply pressure until wood glue dries

Process 6: Cut Slots for hinges

1. Mark locations for slots on ailerons and hinge blocks at least every five inches
2. Use a center scribe to ensure that you are cutting in the center of the part
3. Use a slot cutter to cut slots (Borrowed from Dr Khan)

Process 7: Mount servos

1. Cut scrap balsa to size with a rectangle cut out for the servo mount
2. Drill holes in corners of the rectangular cutout
3. Attach rubber grommet in holes
4. Bolt servo to mount through grommets
5. Use wood glue to attach servo mount (with servo) to wing frame

Process 8: Monokote wing frames

1. Cut a large piece of Monokote that will cover the top or bottom half of the wing surface
2. Use an iron to activate the adhesive and apply to a rib
3. Use a light heat gun to further shrink Monokote and remove bubbles and creases

Process 9: Attach flight surfaces

1. Epoxy hinges into slots. Use Petroleum Jelly to prevent epoxy from gunking up hinge
2. Epoxy Aileron to hinges
3. Epoxy control horns to aileron, be sure that the holes are directly of the hinge axis
4. Cut pushrods to length and use a clevis to connect the control horn to the servo arm

B Fuselage

1 Supplies

- 3D Sheet metal mold file (Inventor)
- Press break (Shop)
- Sheet of 1/64" steel (Shop Scrap)
- Welding equipment (Shop)
- Plasma cutter (Shop)
- Wax (Shop)

- PVA release agent (Amazon)
- Scissors (Shop)
- Paint brush (Amazon)
- Carbon fiber sheets (RockWest)
- Epoxy/Hardener Mix (Shop)
- Latex Gloves (Amazon)
- Bandsaw (Shop)

2 *In House Procedures*

Process 1: Use plasma cutter to make mold

1. Gather all necessary materials for the mold
2. Cut metal to size to be used for exterior mold
3. Send Inventor sheet metal file to Nick
4. Cut the flat mold with the plasma cutter
5. Use sheet metal press break to bend metal to shape
6. Weld corners/ends together as needed
7. Clean up mold with band saw

Process 2: Create carbon fiber belly from mold

1. Cut carbon fiber to length for the carbon fiber belly
2. Wax interior of sheet metal mold
3. Coat inside of mold with epoxy resin/hardener mix
4. Lay carbon fiber onto mold
5. Create batch of epoxy resin/hardener mix
6. Apply mixture to carbon fiber with brush
7. Contour to shape of mold
8. Add additional layers as needed and allow to cure overnight
9. Extract hardened carbon fiber belly from mold and clean up edges with bandsaw
10. Measure and cut holes for engine mount to front of belly

C **Dihedral Joints**

1 *Supplies*

- Two 3/4" width, 1/8" thick aluminum skids
- Two 3/16" shoulder bolts with nuts
- Two 1/2" aluminum tubes
- Two 3/4" OD 1/2" ID aluminum tubes
- Epoxy

2 *In House Procedures*

Process 1: Creating the skids

1. Aluminum scrap was gathered
2. The skids were cut to the appropriate size and length using the bandsaw
3. Using the press break, a 90 degree angle was folded in the skids
4. The "ski" shape was folded by hand
5. A hole was drilled in each skid for the shoulder bolt
6. A supporting joint was cut and welded onto each skid for rigidity

Process 2: Creating the Bent Joint

1. 1/2" OD aluminum tubing was ordered
2. 2 tubes were cut to their appropriate sizes and lengths using the bandsaw
3. The tubes were secured in a clamp at it's halfway point
4. Hammer tubes until at a 5° angle
5. A hole was drilled in each tube for the shoulder bolt
6. Each new feature was deburred

Process 3: Creating the Connector Joint

1. 3/4" OD 1/2" ID aluminum tubing was ordered
2. 2 tubes were cut to their appropriate sizes and lengths using the bandsaw
3. The tubes were secured vertically using v-blocks
4. Ensure the tool head is centered on the tube
5. Use a 35/64" drill and lower it 1.5" into the tube
6. Clamp the tube horizontally
7. Use a 3/4" endmill to cut a flat faced slot into the tube
8. Drill a 3/16" hole in the middle of the slot
9. Deburr all the new features of the connector

D Solar Panel Array

Set up Solar Panel assembly station in Dr. Mark Scott's Lab.

Materials:

- Non-contact soldering iron (Dr. Scott)
- Ventilation fan (Dr. Scott)
- Solder (Dr. Scott)
- Tweezers (Dr. Scott)
- Flux pen (Purchased)
- SunPower C60 Solar cells (Purchased)

- Dog bone metal connection tabs (Purchased)
- Straight edge (Daniel Thompson)
- Latex gloves (Dr. Scott)
- GE Silicone #2 (Purchased)
- Heat gun (MME Lab)
- Backing support (Manufactured in house)

Process 1: Solder two dog bone connection tabs to half of SunPower c60 Solar cells

1. Put on latex gloves
2. Place one solar cell blue-side down on towel on workspace tabletop
3. Use flux pen to apply 1 drop of flux to first connection point
4. Add one dot ($\sim 1\text{mm}^3$) of solder to the connection point using flux tweezers
5. Place one tab of dog bone connection over connection point and align other two tabs with the solar cell connection points
6. Press dog bone onto solder and hold in place
7. Hold non-contact soldering iron 1 cm above the solder point and heat until solder flows (changing color)
8. Repeat steps 3-7 for other two connection points
9. Repeat process for second dog bone connection

Process 2: Solder Solar cells into rows as designated in electrical schematic.

1. Place an un-soldered solar cell (no dog bone tabs attached) blue-side down with positive terminal to the left against straight edge.
2. Place a soldered solar cell (with dog bones attached) in right-neighboring position against straight edge. Align positive terminal to the left so that this terminal will attach to negative terminal of the first cell.
3. Solder the two solar cells together using Process 1
4. Check voltage under constant artificial light to verify efficiency of newly added solar cell. If the cell is a dud (less than 0.4 Voc), unsolder and replace it. Otherwise, continue on to the next step.
5. Add another solar cell in the next right-neighboring position with positive terminal to the left.
6. Solder to the neighboring cell and repeat until the row is complete, checking voltage across each cell to ensure efficiency.
7. Solder on a dog bone connection tab to each end of the row of solar cells if there is not already one present.
8. Repeat process for each row in electrical schematic.
9. Solder on tabbing wires and connection wires to connect all rows in proper orientation.

Process 3: Test each row of solar cells for current and voltage produced in direct sunlight to ensure good soldering connections.

(Move manufacturing process out of Dr. Scott's Lab)

Process 4: Attaching Solar Panels to aircraft

1. Place one dot of GE Silicone #2 in each corner of each solar cell in a single row.
2. Set row into place on plywood top of wing.
3. With support rig in place, lightly press corners of the cell onto the plywood surface and hold in place for 3 minutes to ensure adhesion.
4. Place clear monokote on top of solar cells.
5. Carefully adhere the monokote to the solar cell using an iron on high heat and low pressure.

E Tail

David & Mac

1 Supplies

- 3M 77 Spray Adhesive (Lowe's)
- Wood glue (Ace)
- $\frac{3}{16}$ " balsa sheeting (Hamilton Hobbies)
- Box cutter
- $\frac{1}{4}$ " balsa board (Hamilton Hobbies)
- Balsa flight surface, profiled (Hamilton Hobbies)
- XPS Foam (Amazon)
- Sanding block (Lowe's)
- Scroll saw
- Wax paper (Kroger)
- Masking tape (Ace)
- Poplar block (roughly 2"x4"x6") (Lowe's)
- Nylon hinges (Hamilton Hobbies)
- Nylon control horns (Hamilton Hobbies)
- Threaded A4-40 pushrods (Hamilton Hobbies)
- Clevis (Hamilton Hobbies)
- 4-40 tap and dye (Hamilton Hobbies)
- HS-MG 645 Metal Gear Servos (Hamilton Hobbies)

2 In House Procedures

Process 1: Prepare balsa laminate

1. Cut balsa sheeting to size for the horizontal stabilizer
2. Layer a level surface with wax paper
3. Apply glue to balsa joint. Layer a strip of masking tape over the seam
4. Cover with another sheet of wax paper and compress with soft-cover books for 24 hrs.

Process 2: Cut XPS foam to size

1. Measure and mark foam with sharpie.
2. Use box-cutter on wooden backing board to cut
3. Sand and trim to size as necessary

Process 3: Prepare balsa hinge blocks

1. Measure and mark 1 inch balsa blocks from $\frac{1}{4}$ " sheet
2. Cut blocks using scroll saw
3. Sand as necessary with fine grit

Process 4: Adhere foam surface to laminate

1. In a well ventilated area, apply spray adhesive (3M77) to foam and balsa. Allow it to sit a few seconds until slightly tacky
2. Press surfaces together and apply pressure for 10 minutes

Process 5: Install hinge blocks

1. Apply wood glue to the exposed balsa laminate and one face of the hinge block
2. Ensuring that the grain is transverse the direction of travel, insert the hinge block into the preformed notch
3. Apply pressure and allow to dry for up to 24 hours
4. Sand as necessary to make the balsa and foam surfaces flush

Process 6: Adhere top laminate

1. In a well ventilated area, apply spray adhesive (3M77) to foam and balsa. Allow it to sit a few seconds until slightly tacky
2. Press surfaces together and apply pressure for 10 minutes

Process 7: Prepare spar and rudder blocks

1. Measure, mark, and cut poplar block to billet size
2. Use an end mill or drill press to drill a $\frac{35}{64}$ " through hole. On the second billet, cut a channel for the foam and laminate vertical stabilizer.
3. Sand edges down to an aerodynamic contoured shape, leaving one long surface flat

Process 8: Attach rudder and tail blocks

1. Align and use wood glue to attach the rudder and spar blocks to the balsa laminate surfaces. NOTE: Alignment is critical!
2. Use a long aircraft drill bit to draw a small hole through both blocks and the intermediate laminate and foam.
3. Insert an epoxy coated threaded push rod into the hole and allow to fasten in place (it should be a tight fit)

Process 9: Mount servos

1. Cut an 6"x4" sheet of 1/16" plywood
2. Cut an interior opening in the ply for the servo to fit snugly through
3. Use wood glue to attach the ply over the horizontal laminate and aligned with the previously installed servo blocks
4. Press the servo through the opening and use provided fasteners to mount in the balsa blocks

Process 10: Install hinges

1. Mark 5" spaced locations on hinge blocks for slots to be cut
2. Align and mark the same locations on the elevator and rudder
3. Use a reciprocating slot cutting device to create channels at the marked locations
4. Lubricate the nylon hinge joints with Vaseline
5. Cover the flat hinge surfaces with epoxy and insert into the slotted grooves

Process 11: Attach control horns, pushrods and clevis

1. Mark locations for control horns at the height of the servo arm and so the holes line up with the hinge's rotational axis
2. Use epoxy and 2-56 bolts to attach the control horns to the flight surface
3. Cut 4-40 threaded rods to length so that the flight surfaces have $\pm 45^\circ$ of rotation about the neutral position
4. Thread the bare end of the pushrod with a tap and dye set
5. Thread the rods into a clevis on both ends and pin the clevis to the control horn and servo arm